

RR 2150

Stereo RetroReceiver



Outlaw®

Owner's Manual

Version 1.1

Please Read First



CAUTION: To reduce the risk of electric shock, do not remove the cover. No user serviceable parts inside. Refer to qualified personnel.

WARNING: To reduce the risk of fire or electric shock, do not expose this appliance to rain or moisture.



The lightning flash with arrowhead, within an equilateral triangle, is intended to alert the user to the presence of uninsulated “dangerous voltage” within the product’s enclosure that may be of sufficient magnitude to constitute a risk of electrical shock to persons.



The exclamation point within an equilateral triangle is intended to alert the user to the presence of important operating maintenance (servicing) instructions in the literature accompanying the appliance.

WARNING: Important Safeguards

- **Read Instructions**—All the safety and operating instructions should be read before the unit is operated.
- **Retain Instructions**—The safety and operating instructions should be retained for future reference.
- **Heed Warnings**—All warnings on the unit and in the operating instructions should be adhered to.
- **Follow Instructions**—All operating and use instructions should be followed.
- **Cleaning**—Unplug the unit from the wall outlet before cleaning. The unit should be cleaned only as recommended by the manufacturer.
- **Attachments**—Do not use attachments not recommended by the unit manufacturer as they may cause hazards.
- **Water and Moisture**—Do not use the unit near water—for example, near a bath tub, wash bowl, kitchen sink, or laundry tub; in a wet basement; or near a swimming pool.
- **Accessories**—Do not place the unit on an unstable cart, stand, tripod, bracket, or table. The unit may fall, causing serious injury to a child or adult, and serious damage to the unit. Any mounting of the unit should follow the manufacturer’s instructions, and should use a mounting accessory recommended by the manufacturer.
- **Ventilation**—Slots and openings in the cabinet are provided for ventilation and to ensure reliable operation of the unit and to protect it from overheating, and these openings must not be blocked or covered. The openings should never be blocked by placing the unit on a bed, sofa, rug, or other similar surface. The unit should not be placed in a built-in installation such as a bookcase or rack unless proper ventilation is provided. There should be free space of at least 16 cm (6 in.) and an opening behind the unit.
- **Power Sources**—The unit should be operated only from the type of power source indicated on the marking label. If you are not sure of the type of power supplied to your home, consult your unit dealer or local power company.
- **Grounding or Polarization**—The unit may be equipped with a polarized alternating current line plug (a plug having one blade wider than the other). This plug will fit into the power outlet only one way. This is a safety feature. If you are unable to insert the plug fully into the outlet, try reversing the plug. If the plug should still fail to fit, contact a licensed electrician to replace your obsolete outlet. Do not defeat the safety purpose of the polarized plug.
- **Power-Cord Protection**—Power-supply cords should be routed so that they are not likely to be walked on or pinched by items placed upon or against them, paying particular attention to cords where they enter a plug, or a convenience receptacle, and the point where they exit from the unit.

- **Outdoor Antenna Grounding**—If an outside antenna or cable system is connected to the unit, be sure the antenna or cable system is grounded so as to provide some protection against voltage surges and built-up static charges. Article 810 of the National Electrical Code, ANSI/NFPA 70, provides information with regard to proper grounding of the mast and supporting structure, grounding of the lead-in wire to an antenna-discharge unit, size of grounding conductors, location of antenna-discharge unit, connection to grounding electrodes, and requirements for the grounding electrode.
- **Lightning**—For added protection for the unit during a lightning storm, or when it is left unattended and unused for long periods of time, unplug it from the wall outlet and disconnect the antenna or cable system. This will prevent damage to the unit due to lightning and power-line surges.
- **Power Lines**—An outside antenna system should not be located in the vicinity of overhead power lines or other electric light or power circuits, or where it can fall into such power lines or circuits. When installing an outside antenna system, extreme care should be taken to keep from touching such power lines or circuits as contact with them might be fatal.
- **Overloading**—Do not overload wall outlets, extension cords, or integral convenience receptacles as this can result in a risk of fire or electric shock.
- **Object and Liquid Entry**—Never push objects of any kind into the unit through openings as they may touch dangerous voltage points or short-out parts that could result in a fire or electric shock. Never spill liquid of any kind on the unit.
- **Servicing**—Do not attempt to service the unit yourself as opening or removing covers may expose you to dangerous voltage or other hazards. Refer all servicing to qualified service personnel.
- **Damage Requiring Service**—Unplug the unit from the wall outlet and refer servicing to qualified service personnel under the following conditions:
 - When the power-supply cord or plug is damaged,
 - If liquid has been spilled, or objects have fallen into the unit,
 - If the unit has been exposed to rain or water,
 - If the unit does not operate normally by following the operating instructions. Adjust only those controls that are covered by the operating instructions as an improper adjustment of other controls may result in damage and will often require extensive work by a qualified technician to restore the unit to its normal operation,
 - If the unit has been dropped or damaged in any way, and great care should be exercised in handling, and the unit should be examined by qualified service personnel.
- When the unit exhibits a distinct change in performance—this indicates a need for service.
- **Replacement Parts**—When replacement parts are required, be sure the service technician has used replacement parts specified by the manufacturer or have the same characteristics as the original part. Unauthorized substitutions may result in fire, electric shock, or other hazards.
- **Safety Check**—Upon completion of any service or repairs to the unit, ask the service technician to perform safety checks to determine that the unit is in proper operation condition.
- **Wall or Ceiling Mounting**—The unit should be mounted to a wall or ceiling only as recommended by the manufacturer.
- **Heat**—The unit should be situated away from heat sources such as radiators, heat registers, stoves, or other units (including amplifiers) that produce heat.

IMPORTANT SAFETY NOTE

Before connecting a new component such as the RR 2150 to your audio or home theater system it is always good practice to make certain that all components are turned off, and preferably unplugged from their AC power source. Many modern electronics products feature automatic turn-on circuits that may be activated during an installation, causing the potential for damage to electronic components and/or speakers. Such damage is not covered by product warranties and Outlaw Audio specifically disclaims responsibility for any such damage.

Precautions

Verify The Line Voltage

Your new RR 2150 has been factory configured for 120 (+/- 3%) volt AC lines. Connecting the unit to a line voltage other than that for which it is intended can create a safety and fire hazard, and may damage the RR 2150. If you have any questions about the voltage requirements for your specific model, or about the line voltage in your area, contact Outlaw Audio before plugging the unit into a wall outlet.

NOTE: It is always a good idea to avoid using any audio or video equipment on the same AC circuit as equipment with motors, such as air conditioners or refrigerators. This will lessen the possibility of power variation and electrical start-up noise affecting your sound system.

Power Cord

The removable power cord that is shipped with the RR 2150 is specifically designed to be used with this product. DO NOT use any other power cord, as that may reduce the unit's performance and possibly create a safety hazard. In particular, DO NOT use standard IEC type power cords designed for computers and other business equipment products, as they have a three prong plug that is not meant for use with the RR 2150. Should the power cord require replacement, use an identical type, or contact Outlaw Audio for service.

Handle the AC Power Cord Gently

When disconnecting the power cord from an AC outlet, always pull the plug, never pull the cord. If you do not intend to use the RR 2150 for any considerable length of time, disconnect the plug from the AC outlet. If the power cord is replaced, make certain that it is of similar gauge. As with all electrical devices, do not run power cords under rugs or carpets or place heavy objects on them. Damaged power cords should be replaced immediately with cords meeting factory specifications.

AC Fuse

The fuse is located inside the chassis and is not user-service-able. If power does not come on, contact your authorized service station.

Wiring

Cables that are run inside of walls should have the appropriate markings to indicate compliance with, and listing by the UL, CSA or other standards required by the UL, CSA, NEC or your local building code. Questions about cables inside of walls should be referred to a qualified custom installer, or a licensed electrician or low-voltage contractor.

Installation Location

To assure proper operation and to avoid the potential for safety hazards, place the unit on a firm and level surface capable of supporting its weight. When placing the unit on a shelf, be certain that the shelf and any mounting hardware can support the weight of the unit and any additional items in the equipment rack, or on the shelf.

When positioning the RR 2150 in its final location, make certain that it has adequate ventilation on all sides, as well as on the top and bottom. In particular, it is a good idea to provide at least two or three inches of room above the unit for air circulation. DO NOT place CDs, DVDs, videotapes, owner's manuals, or other paper on top of, or beneath, the unit, or in-between multiple amplifiers in a stack. This will block airflow, causing heat build-up, degraded performance, and may create a possible fire hazard.

If the unit is to be enclosed in a cabinet or rack, make certain there is adequate air circulation. Sufficient ventilation should be provided so that hot air may exit, and cool air may enter the cabinet. In some instances, a small cooling fan may be required to insure adequate airflow through the cabinet. If you are in doubt as to the ventilation requirements for your specific installation, please contact us. Also, do not place the RR 2150 directly on a carpeted surface, as this will inhibit airflow underneath as well as create a potential fire hazard.

Avoid installation in humid locations, in extremely hot or cold locations, or in areas that are exposed to direct sunlight or space heating equipment.

Do Not Open The Cabinet

There are no user serviceable components inside this product. Opening the cabinet may present a shock hazard, and any modification to the product will void your guarantee. If water or any metal object, such as a paper clip, coin or a staple, accidentally falls inside the unit, disconnect it from the AC power source immediately, and contact Outlaw Audio for further instructions.

Recording Copyright

Recording of copyrighted material for other than personal use is illegal without permission of the copyright holder.

Note to CATV system installer

This reminder is provided to call the CATV system installer's attention to Article 820-40 of the NEC, ANSI/NFPA 70, which provides guidelines for proper grounding and, in particular, specifies that the cable ground shall be connected to the grounding system of the building, as close to the point of cable entry as practical.

FCC Information for User

CAUTION: ANY changes or modifications not expressly approved by the party responsible for compliance could void the user's authority to operate the equipment.

NOTE: This equipment has been tested and found to comply with the limits for a Class B digital device, pursuant to Part 15 of the FCC Rules. These limits are designed to provide reasonable protection against harmful interference in a residential installation.

This equipment generates, uses and can radiate radio frequency energy and, if not installed and used in accordance with the instructions, may cause harmful interference to radio communications. However, there is no guarantee that interference will not occur in a particular installation.

If this equipment does cause harmful interference to radio or television reception, which can be determined by turning the equipment off and on, the user is encouraged to try to correct the interference by one or more of the following measures:

- Reorient or relocate the receiving antenna.
- Increase the separation between the equipment and receiver.
- Connect the equipment into an outlet on a circuit different from that to which the receiver is connected.

Outdoor Antenna Installation

Safe Antenna and cable Connection

If an outside antenna or cable system is connected to the equipment, be sure the antenna or cable system is grounded so as to provide some protection against built up static charges and voltage surges. Section 810 of the national Electrical Code, ANSI/NFPA 70 (in Canada, part 1 of the Canadian Electrical Code) provides information with respect to proper grounding of the mast and supporting structure, grounding of the lead-in wire to an antenna discharge unit, size of grounding conductors, location of antenna discharge unit, connection to grounding electrodes and requirements for the grounding electrode.

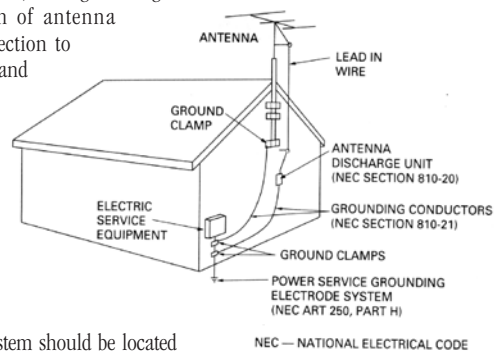

Keep Antenna Clear of High Voltage Power Lines or Circuits

An outside antenna system should be located well away from power lines, electric light or power circuits and where it will never come into contact with these power sources if it should happen to fall. When installing an outside antenna, extreme care should be taken to avoid touching power lines, circuits or other power sources as this could be fatal. Because of the hazards involved, antenna installation should be left to a professional.

Table of Contents

2	Please Read First
4	A Brief Note On This Manual
4	Serial Number
5	A Quick Guide to the RR 2150's Features
5	Unpacking
5	Accessories
6	RR 2150 Front Panel
7	RR 2150 Rear Panel
9	Remote Control
10	Connecting Your RR 2150
10	Connecting and Using Antennas
11	Connecting Source Components
13	Loudspeaker Connections
15	Subwoofers and Bass Management Settings
16	External Amplifier Connections
16	12 Volt Trigger
16	AC power connection
18	Operation
18	Power
18	Choosing a Source
18	Using the Volume Control
18	Muting the Volume
18	Speaker A/B Selection
18	Speaker EQ
19	Adjusting Tone Controls
19	Balance Adjustment
19	Using Headphones
19	Recording
20	Using the AM/FM Tuner
22	Programming the Remote Control
22	Setup using Preprogrammed Codes
22	Searching for Unknown Codes
22	Some General Comments on Using Your Remote
23	Care and Maintenance
23	Cleaning
23	When You're Away
23	Troubleshooting
24	Setup Codes
27	RR 2150 Specifications
28	Outlaw Audio Limited Warranty

Outlaw Audio RR 2150 Stereo RetroReceiver

Welcome to the Hideout – with the purchase of a RR 2150 RetroReceiver you're now an Outlaw! Although you've selected one of the most advanced audio components available today, being an Outlaw isn't always easy. Owning Outlaw components often ruffles the feathers of friends or acquaintances who don't. That's because Outlaw products outperform comparably priced units from virtually all other companies or cost much, much less than units offering similar performance. But that's what being an Outlaw is all about. So, once again, welcome. And our thanks for joining the gang. We think you're going to enjoy being an Outlaw.

Your new Outlaw Audio RR 2150 RetroReceiver is a full-featured stereo receiver that has exterior styling inspired by the art deco table radios of the past matched with totally up-to-date circuitry, parts selection, and assembly techniques to assure state-of-the-art audio performance and convenience. The RR 2150 combines a broad range of inputs and outputs with a flexible, yet simple to use control system with a powerful, no-nonsense amplifier that will make your speakers deliver all the sound they're capable of.

A Brief Note On This Manual

Read it! It's that simple. OK, we know that Outlaws are a contrary bunch and some of you won't, but those who take the time to read this manual will get some serious help craftily disguised in non-serious language. You might say that this manual is different from those you've encountered in the past.

The Manual contains everything you need to know to connect, configure, and use your new receiver. It will show you how to integrate your new receiver with all the other components in your system, and how to customize the RR 2150 to match your preferences.

If you still have questions, we're not going to leave you staked out in the sun waiting for some posse to round you up. You can contact us via e-mail at information@outlawaudio.com or call us at **1-866-OUTLAWS** (688-5297).

You may also find fellow Outlaws hanging out around the campfire at the Outlaw Saloon. It's a great place to hang out and share your RR 2150 experiences with like minded folk. Mosey on in by clicking on "Outlaws' Hideout" on our home page and then clicking on "Outlaw Saloon."

Serial Number

Take a moment to record your RR 2150's serial number and date of purchase here. The serial number is found on the back panel.

Serial Number _____

Date of Purchase _____

The contents of this manual are Copyright © 2005 by Outlaw Audio, LLC, and may not be duplicated or reproduced by any means, whether physical, electronic or otherwise without prior written consent from Outlaw Audio.

A Quick Guide to the RR 2150's Features

We'll explain how to benefit from all of these features further on in the Manual, but we wanted you to know about them beforehand so you can watch for those you're particularly interested in.

- **High Power Stereo Amplifier**
2 x 100 watts continuous power, 20 Hz to 20 kHz @ 8 ohms, <0.03% THD, both channels driven
- **6 Analog Inputs**
Connect all of your audio sources with ease. Included are a rear panel Phono input (moving coil or moving magnet), Video, CD, Tape, and External Processor Loop and a front panel 3.5 mm Auxiliary input suitable for iPod or MP3 player.
- **1 Rear Panel USB Input**
Connect a USB-enabled device (streaming audio from a compatible computer, etc.) for playback through your main music system.
- **Separate Signal Paths for Listening and Recording**
Listen to one source while recording another.
- **Preamp Outputs and Main Amplifier Inputs**
These enable easy system configuration with additional power amplifiers, electronic crossovers, equalizers, etc.
- **Separate Line-level Subwoofer Output with Bass Management**
Includes precision analog Bass Management for easy subwoofer connection. The internal crossover is a symmetrical 2nd order (12 dB/octave) Butterworth filter set.
- **A/B Speaker Selector Switch**
- **Front Panel Adjustable Speaker Equalization**
This selector adds a half-octave of bass boost at selected frequencies for better bass response with compact bookshelf speakers.
- **Front Panel Tone Control Defeat**
- **High-performance AM/FM/STEREO Stereo Tuner with 39 Presets.**
- **Audiophile-quality Preamplifier and Power Amplifier Stages**
Necessary for critical music listening.
- **Headphone jack with level control.**
- **12 Volt Trigger**
Use this output for control of external system components (amplifier, video projector, etc.) so they turn on any off in sync with your RR 2150.
- **Infrared (IR) Input and Output**
Use these to control your RR 2150 even when it is hidden behind closed doors – not that you'd ever want to do that!
- **Precision, Motorized Volume Control**
- **Removable IEC-style Power Cord**
- **Multi-device, Programmable Remote Control**

Unpacking

Your receiver comes in a carton with packing materials designed to cushion it from all the rudeness it'll undoubtedly encounter during shipping. We strongly suggest you save all this for use if you move, or if the unit ever needs to be shipped back to us for any reason.

You can minimize the size of the carton for storage. Flatten it by carefully opening the top and bottom flaps and folding the carton flat. Do the same with other cardboard inserts. If some packing material can't be folded, save it in a plastic bag.

The RR 2150 is not light. So take care when you lift it. Use your legs, not your back! And don't bash the protruding front-panel volume control knob or the rear-panel connectors.

Accessories

After unpacking your RR 2150, please check it make sure that the following accessories are in the box:

- 1 Remote control
- 2 AA Batteries for the remote control
- 1 AC power cord
- 1 FM antenna
- 1 AM loop antenna
- 2 U-shaped jumpers
- 1 Owner's manual

RR 2150 Front Panel

FP1 Tone Off (Defeat) control (see page 19)

Press this button to take the tone controls out of the signal path so that they have no effect regardless of where they're set. The blue LED in the button's center will glow when the tone controls are inactive.

FP2 Bass control (see page 19)

Turn this knob to change the amount of low frequency information being sent to your speakers or headphones. The bass control is inactive when the Tone Off button (FP1) is depressed.

NOTE: When using small speakers – those with limited bass handling capability – be careful when increasing bass content, particularly if you've also selected any setting other than "Off" with the front panel Speaker EQ switch (FP15).

FP3 Balance control (see page 19)

Turn this knob to adjust for left-right imbalances in a source.

FP4 Front Panel Display

This display shows the selected input or radio station currently tuned, as well as menu items to help you use the RR 2150.

FP5 Treble control (see page 19)

Turn this knob to change the amount of high frequency information being sent to your speakers or headphones. The treble control is inactive when the Tone Off button (FP1) is depressed.

FP6 Tuning Up (Menu Select) (see pages 20-21)

Press this button to tune to a broadcast frequency higher than the one currently selected. It is also used with the Function and Enter pushbuttons (FP8 and FP9 respectively) to adjust tuner functions to match your preferences.

FP7 Tuning Down (Menu Select) (see pages 20-21)

Press this button to tune to a broadcast frequency lower than the one currently selected. It is also used with the Function and Enter pushbuttons to adjust tuner functions to match your preferences.

FP8 Function button (see pages 20-21)

This button is used to configure the RR RR 2150's internal tuner.

FP9 Enter button (see pages 20-21)

When setting up tuner functions with the Function (FP8) and the Tuning Up and Down buttons (FP6 and FP7 respectively), press this button to enter the choice shown to the unit's memory.

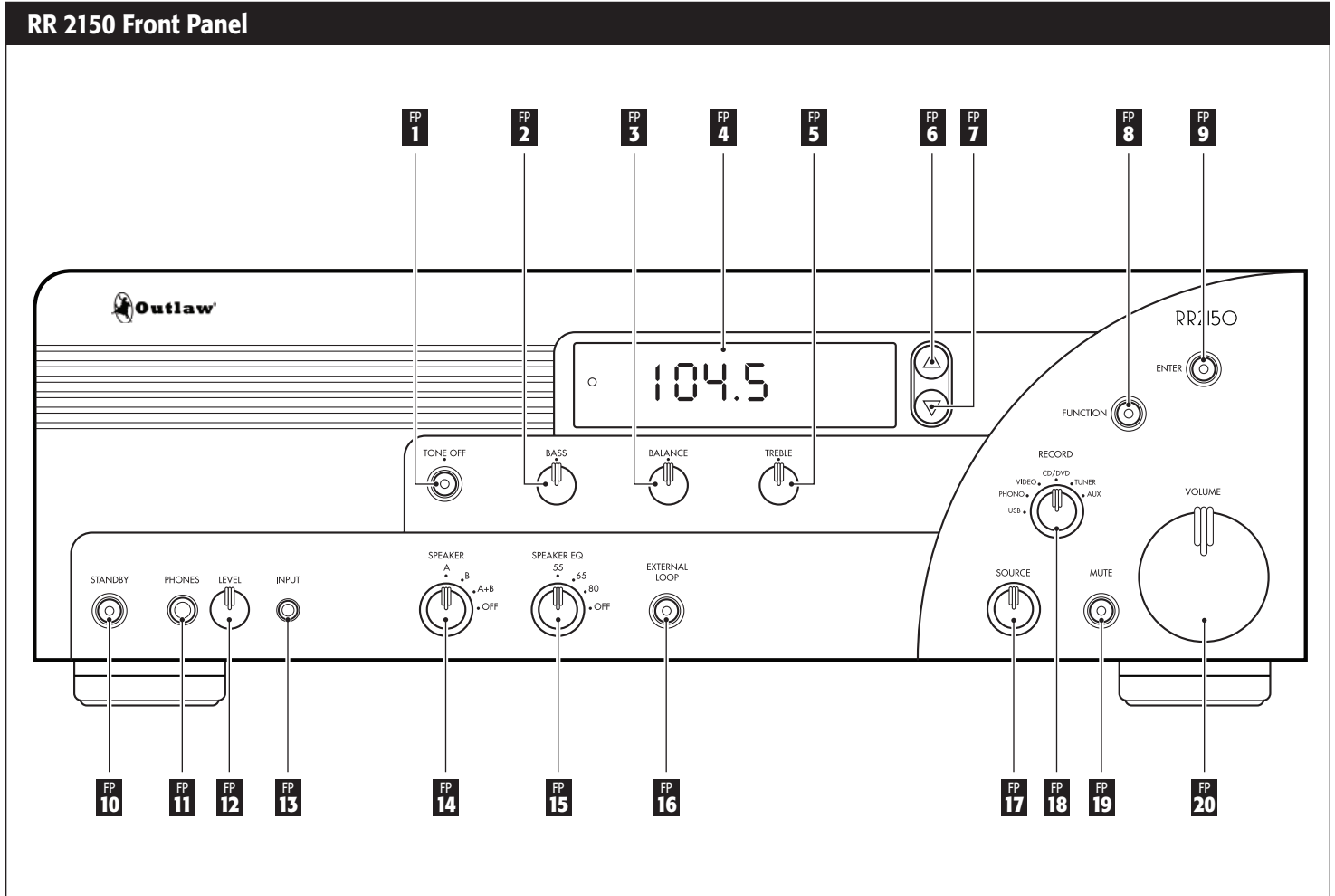

FP10 On/Standby button (see page 18)

When the RR 2150 is plugged in and the Master Power switch (RP8) is On, pressing the front panel On/Standby button will toggle the unit from standby condition (everything off except for the IR sensor and associated circuitry) to fully operational. When the unit is in standby mode, the pushbutton's blue LED will light.

FP11 Headphone Jack (see page 19)

Plug a 1/4 inch phone plug (or an adaptor) here for headphone listening.

FP12 Headphone Level Control (see page 19)

Turn this knob to control headphone volume.

FP13 Aux Input Jack (see pages 11-12)

Use this stereo 3.5 mm jack to plug in any portable audio device with a headphone or line-level output.

FP14 Speaker Selector Switch (see page 18)

When two pairs of speakers are connected to the RR 2150, this switch lets you select which pair, or both, is active.

FP15 Speaker EQ Selector (see pages 18-19)

Turn this switch to add a moderate amount of bass boost (+6 dB at 55, 65, or 80 Hz) to compensate for speakers with limited bass output.

NOTE: We suggest that you leave this selector in the "Off" position if you've turned the bass tone control all the way up. Although it's unlikely that you'll damage your speakers, you may hear some real nastiness.

FP16 External Loop Select button (see pages 11-13)

Press this switch to add a product connected to the rear panel External Processor Loop connections (RP14) to the signal path. (Remember to turn that external unit on!) The button's blue LED will light when you've chosen this optional signal path.

NOTE: When the signal is routed through the External Processor Loop and there is no unit connected to the jacks, no signal will appear at either the loudspeaker or headphone outputs.

FP17 Source Selector (see pages 18-20)

Turn this knob to select the input source (FM, AM, CD/DVD, Video, Phono, USB, Tape, or the front panel Aux input) that you want to LISTEN to.

FP18 Record Selector (see page 19)

Turn this knob to select the source you want to RECORD. Your selection will appear only at the rear panel's Tape Out jacks (RP13).

FP19 Mute On/Off button (see page 18)

Press this button to mute the speaker outputs. The button's blue LED will blink when Mute is engaged. Turning the Master Volume control has no effect on Mute. You have to turn Mute off by pressing the button again.

FP20 Master Volume control (see page 18)

Turn this knob to the right (clockwise) to increase volume and to the left (counterclockwise) to decrease levels.

RR 2150 Rear Panel

RP1 Ground connector (see pages 11-12)

Connect the ground wire from your turntable to this screw connector.

RP2 FM Antenna connection (see page 10)

Connect the supplied FM antenna or an optional external FM antenna to this connector.

RP3 AM Antenna connections (see page 10)

Connect the supplied AM loop antenna to these terminals.

RP4 IR (infrared) In/Out Connectors (see page 22)

When your RR 2150 is hidden behind doors that prevent the remote control from "seeing" the front panel IR sensor, you may connect an optional, external IR sensor to this 3.5mm mini-plug. To send the IR signal to another product in a "daisy change" configuration, connect the IR Out jack to another product with a compatible IR system.

RP5 12 volt trigger output (see pages 16-17)

This 3.5mm mono mini-jack provides a turn-on and turn-off pulse that may be used to control optional external amplifiers from Outlaw and other brands, as well as other compatible accessories.

RP6 USB connector (see pages 11-12)

Connect the USB output of a compatible computer or MP 3 audio player to this jack for high fidelity playback.

RP7 Serial number

Write this number in the space provided on page 4 for future reference.

RP8 Master Power switch (see page 18)

When the power cord has been plugged into an AC output, put this switch in the On position to connect the receiver to AC. When this switch is on, the front panel On/Standby pushbutton (FP10) is used to turn the receiver "on" or place it in the "standby" mode.

RP9 Phono cartridge sensitivity selector switch (see page 11)

This switch adjusts the phono pre-amp to work with either moving magnet (MM) or moving coil (MC) phono cartridges. Set it to correspond with the type of cartridge you're using.

RP10 Phono inputs (see pages 11-12)

Plug your turntable's output cables into these jacks.

RP11 Analog audio inputs for video source (see pages 11-12)

Connect the output of any line-level audio source such as a DVD player, VCR, satellite or cable box to this jacks.

RP12 CD/DVD analog audio inputs (see pages 11-12)

Connect the analog audio output of your CD or DVD to these jacks.

RP13 Tape Loop connections (see pages 11, 13)

Connect your recording device's analog audio outputs and inputs to these jacks.

NOTE: These are fixed-level outputs and are not affected by the RR 2150's volume control. If you're using a portable recording device (MiniDisc recorder, etc.), you may a shielded stereo "Y" cords (3.5 mm stereo miniplug to two RCA-type jacks) to go from it to the RR 2150.

RP14 External Processor Loop connections (see pages 11, 13)

Connect an external processor (equalizer, electronic crossover, surround processor, etc.) to these jacks. These outputs are also fixed-level.

RP15 Bass Management selector switch (see page 15)

This switch lets you adjust the internal crossover (bass management system) to route user-selected low frequencies to the subwoofer output (RP18) while the rest of the audio signal is sent to the amplifier and then to the main loudspeakers.

RP16 Preamplifier outputs (see pages 16-17)

These outputs allow you to connect a high output power amplifier if needed. Simply remove the jumpers and connect the preamp outputs to the inputs of the additional amplifier.

NOTE: Removing the jumpers ordinarily means that the RR 2150's internal amplifier does not receive a signal and thus can not send any output to the speakers you have connected to it. In unusual circumstances, you can use shielded "Y" cords to connect both the internal amplifier and another amplifier to the receiver's preamp section.

RP17 Main amp inputs (see pages 16-17)

These inputs are normally connected to the preamplifier outputs by jumpers. (See RP16 above.)

RP18 Subwoofer line level output (see pages 14-15)

Connect a powered subwoofer to this output. Make sure you've set the Bass Management selector switch (RP15) correctly. The output from this connector is variable and controlled by the Master Volume setting (FP20).

RP19 Loudspeaker outputs (see pages 13-15)

Use these binding posts to connect your primary (Speakers A) and secondary (Speakers B) loudspeakers to the RR 2150.

RP20 AC socket (see page 16)

Connect the supplied AC power cord to this socket before turning on the Master Power Switch (RP8).

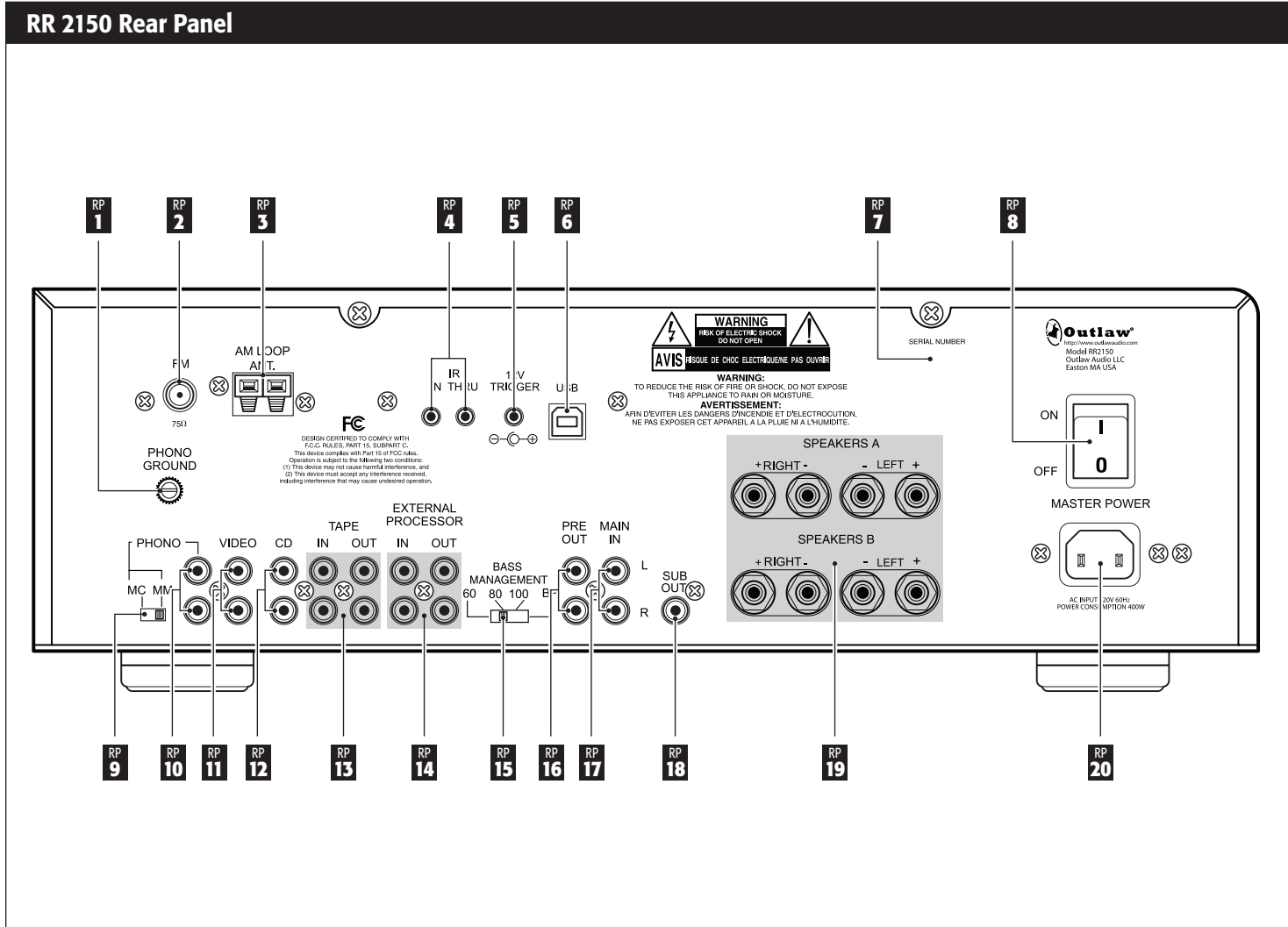

Remote Control

RC1 Setup button (see page 22)

To begin programming the remote for command codes for a device, press this button for three seconds until the Indicator LED (RC15) lights.

RC2 Device control selector pushbuttons (see pages 20-22)

Press one of these buttons to select the component you want to control with the remote. Press RR to control the RR2150.

RC3 Numeric keypad buttons (0 thru 9) (see pages 20-22)

Press these buttons to enter numbers for different functions such as direct input of station frequencies for the internal tuner, and other numeric functions for products such as DVD and CD players. These buttons are also used to enter command codes when programming the remote.

RC4 Mute (see page 18)

Press this button to mute the receiver's output. Another push restores volume to its previous level. The blue LED in the center of the front panel's Mute button (FP19) lights whenever Mute is engaged.

RC5 Volume Up/Down pushbuttons (see page 18)

Press these buttons to raise or lower the volume.

RC6 Sleep (see page 20)

Press this button to activate the sleep function, which turns the RR 2150 off after a user-selectable amount of time.

RC7 Guide

This button has no function for the RR 2150. For other components, it will normally activate the information guide, if available, though the function may vary from device to device.

RC8 Cursor control buttons (menu navigation) (see pages 20-22)

RR 2150: The Left and Right buttons have no function for the RR 2150. When the tuner is in use, the Up and Down buttons have the same functions as the front panel Up and Down buttons. Press these in conjunction with the Function and Enter buttons to adjust tuner functions.

Other components: For other devices these buttons will normally move the cursor in an on-screen menu up or change menu settings, though their function may vary from device to device.

RC9 Info button

This button has no function for the RR 2150. For other components, it will display an information menu, though the function may vary from device to device.

RC10 Transport Control buttons

These buttons have no function for the RR 2150. Use these buttons for components with transport and recording controls, such as a VCR. Their function may vary from device to device.

RC11 Source (or input) selector buttons (see pages 18-19)

Press the button corresponding to the name of the input you wish to select for listening. Pressing one of these buttons will also turn the RR 2150 on when it is in the Standby Mode.

RC12 AM/FM button (see pages 20-21)

Press this button to select the AM/FM tuner when using another source. Press it again to switch between AM/FM.

RR2150 Remote Control

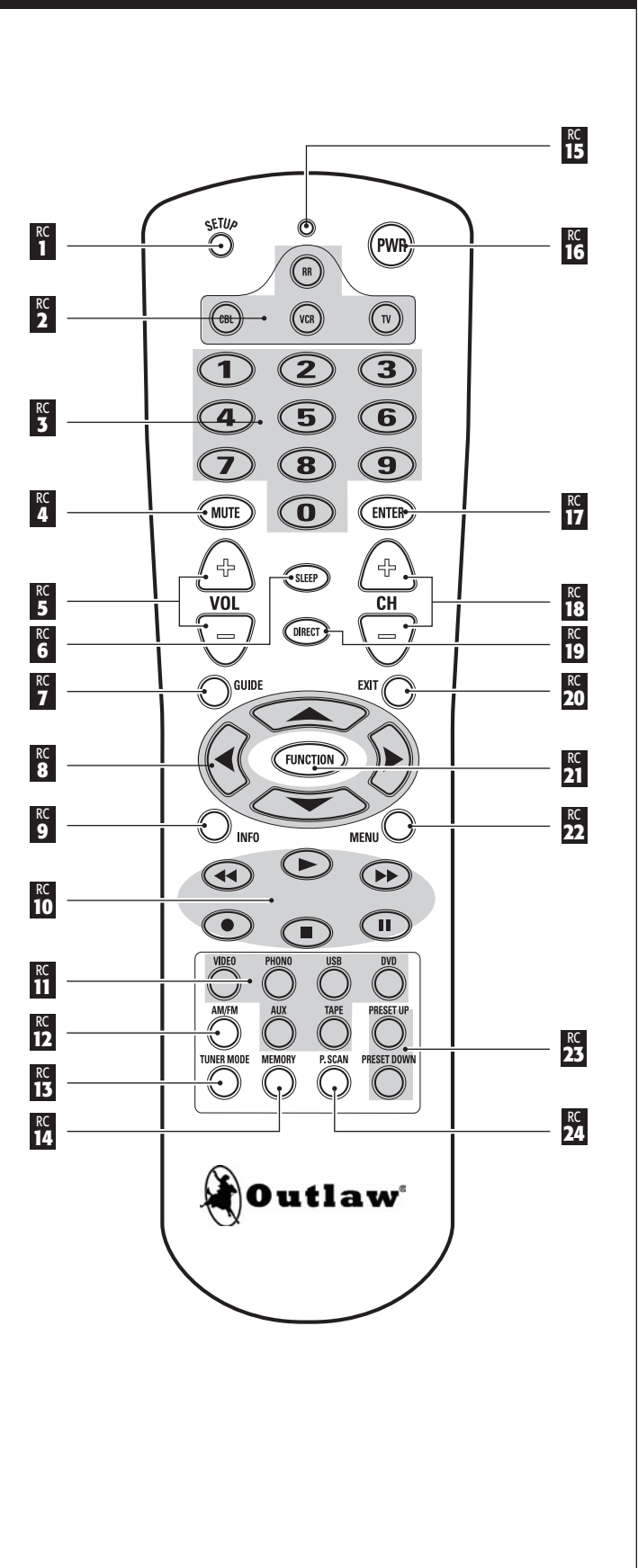

RC13 Tuner Mode button (see page 20)

This button selects either the “FM Stereo” or “FM Mono” tuner mode.

RC14 Memory button (see page 21)

Press this button to begin the process of entering a radio station's frequency into the tuner memory for quick recall.

RC15 Indicator LED (see page 22)

This lights briefly when you push a control key to tell you that the remote has responded to your request. The Indicator LED flashes twice in rapid succession when you've successfully entered “setup” mode.

RC16 Power (off button) (see page 18)

Press this button to turn off the RR 2150, or the device currently being controlled by the remote.

NOTE: This is a “Power Off” button only. To turn the RR 2150 on, press any Source Selector button (RC11). This will turn the unit on and select the input you've pushed.

RC17 Enter dual function button (see pages 20-21)

RR 2150: This button duplicates the functions of the front panel Enter button (FP9). Press it to enter a selection when programming the RR 2150's tuner functions.

Other components: The function depends on selected component.

RC18 Channel Up/Down dual function buttons (see pages 20-21)

RR 2150: When the tuner is in use, press these buttons to go the next higher or lower broadcast frequency

Other components: The function depends on selected component.

RC19 Direct dual function button (see pages 20-21)

RR 2150: Pressing this button starts the process of selecting a broadcast station directly. Within five seconds of pressing the button, key in a particular broadcast frequency with the numeric keypad (RC3).

Other components: The function depends on selected component.

RC20 Exit button

This button has no function for the RR 2150. For other components, it will exit an active menu screen, though the function may vary from device to device.

RC21 Function button (see pages 20-21)

RR 2150: When the tuner is in use, this button is used to configure the RR 2150's internal tuner.

Other components: Its function will vary from device to device.

RC22 Menu button

This button has no function for the RR 2150. For other components, it will display a setup menu, though the function may vary from device to device.

RC23 Preset Up and Down buttons (see page 21)

Press this button to scan up and down through the list of radio station frequencies you have programmed into the RR 2150.

RC24 P. Scan button (see page 21)

Press this button to begin a scan of all stations programmed into the RR 2150's memory system.

Connecting Your RR 2150

Before trying to connect your RR 2150 to other system components, please observe the following simple precautions:

- Don't connect the power cord to either the AC outlet or your RR 2150 until you've made all other connections.
- Always turn off any device before connecting it to the RR 2150. Better yet, unplug the device from its AC power source, as automatic turn-on signals may inadvertently turn the product on. Better safe than sorry!
- Always pay attention to the warnings, options, and specific procedures contained in the instructions that came with the component you're connecting.
- For analog connections, remember that
red input jacks = right channel audio
white input jacks = left channel audio
- Insert all plugs and connectors securely. If you don't, you may experience noise, poor performance, or equipment damage.
- DO NOT bundle audio connection cables with power cords and speaker cables. To get the performance you expect, run all the power cords down one side of the cabinet, all the signal connections down the other side, and the speaker cables down the center.
- Connect your speakers after you've connected all your other components to the RR 2150 but before you connect the power cord.

Connecting and Using Antennas

The RR 2150 has an internal AM/FM tuner with separate connections for the AM and FM antennae.

FM Antenna

Connect the supplied FM dipole antenna by pushing the antenna's coaxial connector onto the FM antenna connector (RP2.)

NOTE: This antenna is for indoor use only. For best reception, fully extend the antenna and experiment with its positioning to get the strongest signal. If FM reception with the supplied indoor antenna does not provide a strong enough signal for acceptable reception, we recommend using an optional amplified indoor or high-gain outdoor antenna.

AM Antenna

Connect the supplied AM antenna to the rear panel push terminals (RP3). Press one lever on the bottom of the terminal block and insert one of the antenna wires. Release the lever and repeat the process with the other wire and lever. Experiment with the antenna's position to obtain the strongest signal.

Connecting Source Components

Connect your input sources as shown below. Once the source is connected you may select it by pressing the front panel Source selector (FP17) to step through your various input choices. The RR 2150 will show which input is currently enabled by displaying the name on the front panel display.

Phono

Plug your turntable's output cables into the L/R Phono inputs (RP10). Make sure you've connected Left to Left and Right to Right. Next, attach the ground connection from your turntable's tonearm to the ground connector screw terminal (RP1).

Finally, set the phono cartridge sensitivity selector switch (RP9) to either MM (moving magnet) or MC (moving coil) to correspond with the type of cartridge you are using. Note that some high output moving coil cartridges work better when this selector is set to MM.

USB

Use a "fast USB" cable to connect a compatible USB-enabled source component to the RR 2150's rear panel USB 2.0 input (RP6).

Tape

Using shielded RCA-to-RCA cables, connect your recording device's analog audio outputs to the RR 2150's L/R Tape inputs (RP13). Next, connect your recording device's analog audio inputs to the RR 2150's L/R Tape outputs (RP13).

There are two further points you need to remember:

- The tape outputs "fixed-level" in that they are not affected by the RR 2150's volume control.
- You must select the source you want to record by using the front panel Record Selector (FP18).

If your recording device has the 3.5 mm stereo miniplugs often used on portable audio products, use an optional adaptor cable to complete your connections.

Aux

Connect a portable music player (iPod®, MP3 player, etc.) or any other playback device with a stereo 3.5 mm jack for either headphone or line-level output to the RR 2150's front panel Aux input (FP13).

CD/DVD

Using shielded RCA-to-RCA cables, connect your CD or DVD player's analog audio outputs to the RR 2150's CD/DVD inputs (RP12). As with other sources, make sure to connect Left to Left and Right to Right.

Video

Connect the analog line-level audio output from any A/V source (VCR, satellite or cable box, etc.) to the Video input jacks (RP11) using shielded RCA-to-RCA cables.

NOTE: The RR 2150 does not have any inputs for the video from a DVD player or other video source device. Any video connections should be made directly to the an appropriate input on your display device.

External Loop

This external processor loop (RP14) allows you to insert a wide variety of external devices such as equalizers or surround processors into the RR 2150's signal path. However, its use is optional. If your system doesn't need the added flexibility, make sure that the blue LED in the External Loop button (FP16) is not illuminated. Since the External Loop may be switched in or out, it is best suited to devices that you might use with some input sources, but not all.

Using shielded RCA-to-RCA cables, connect the external processor's analog audio outputs to the RR 2150's L & R analog audio inputs. Next, connect the external processor's analog audio inputs to the RR 2150's analog audio outputs.

Remember these two points.

- You must push the front panel External Loop button (FP16) to route the audio signal to and from the external processor. The button's blue LED will light when the external loop is active.
- The external processor loop is a "fixed level" loop. It is not affected by the RR 2150's Master Volume Control.

Preamplifier Outputs/Main Amplifier Inputs

The RR 2150 is shipped with U-shaped jumpers that connect the preamplifier and power amplifier sections of the receiver. For most systems no change is needed here, as you will use both sections of the RR 2150. However, if you wish to use an optional, external amplifier, remove the jumper plugs and connect the left and right output jacks on the RR 2150 to the matching inputs on your amplifier. Save the jumper plugs for use should you later wish to return to normal operation.

These jacks also provide a means to insert an equalizer or other device controller in the audio signal path when you wish to have that device ALWAYS be used. A good example of this is the external equalizer/controller used with certain brands of speakers.

To connect an external processor so that it is always in the audio path, remove the two U shaped jumpers, but save them should they be needed in the future.

Connect the RR 2150's L & R Preamp audio outputs (RP16) to the inputs of the external processor. Next, connect the outputs of the external processor to the RR 2150's Main amp audio inputs (RP17).

Connecting Audio Equipment to the RR 2150

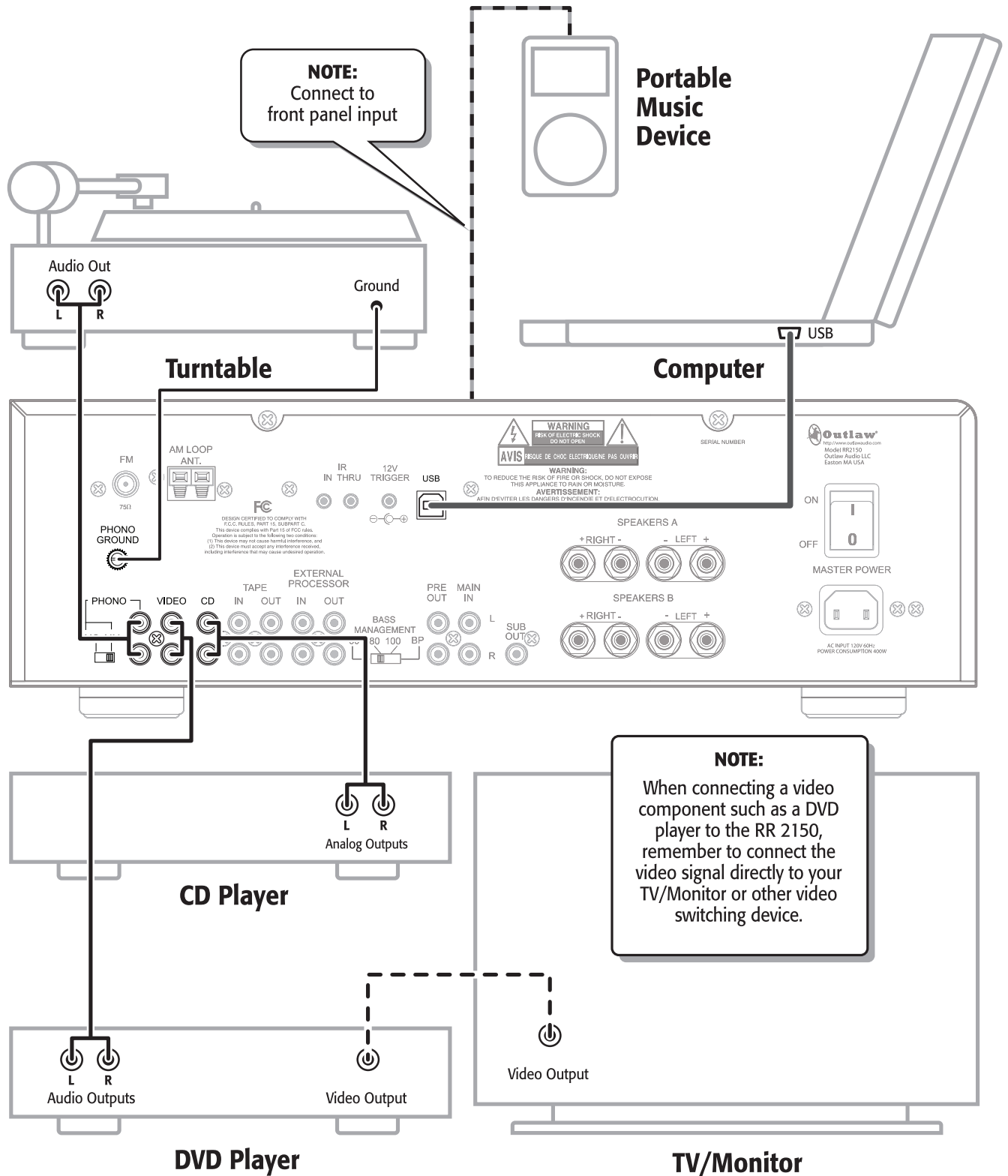

Connecting Audio Recording Equipment and an External Processor to the RR 2150

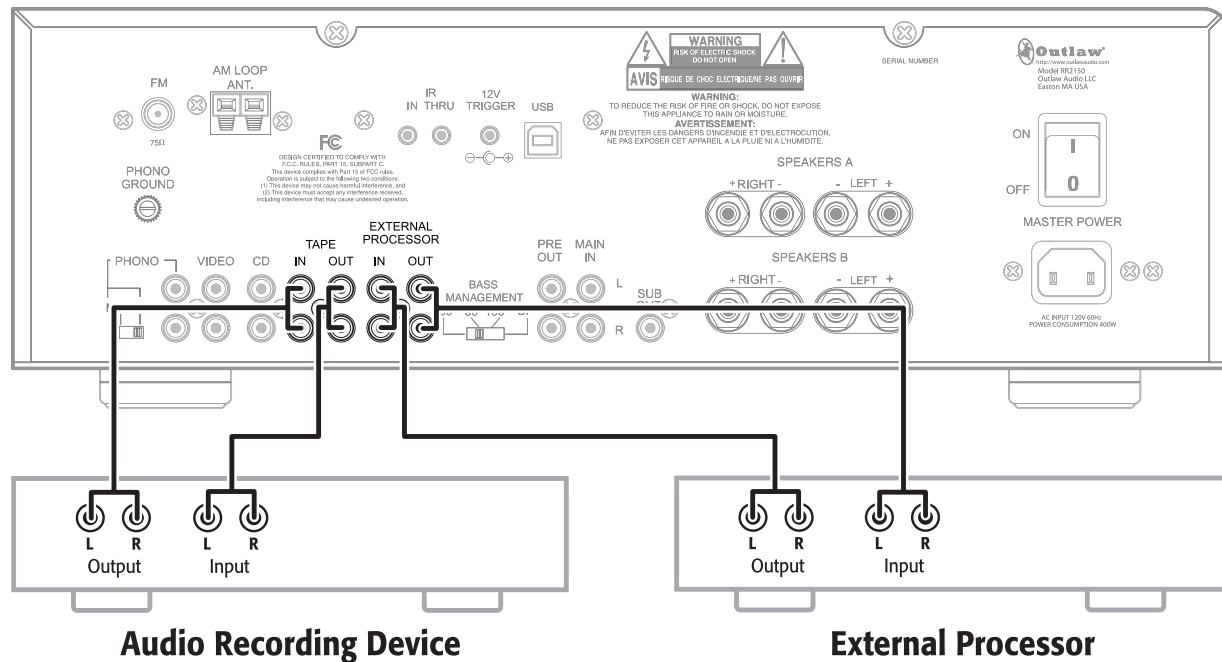

Loudspeaker Connections

The connections between the RR 2150 and your loudspeakers are critical to good sound. Although there's a lot of debate about the "best" speaker wire and the "best" connectors, our advice is to use what you feel is appropriate. However, we do feel that there is one vital guideline: If the run from your RR 2150 to a speaker is less than 40 feet, use speaker wire with a conductor diameter that's identified as "16 gauge" or lower. For longer runs, use a minimum of 14 gauge wiring.

If you're confused by the "gauge," you're not alone. The standard in wire measurements is called AWG, or American Wire Gauge. The AWG number refers to the diameter of one conductor only (speaker wire has two conductors) and smaller gauge numbers mean larger conductors. Here's a short list of gauge numbers and their corresponding diameters:

12 gauge	.0808"
14 gauge	.0641"
16 gauge	.0508"
18 gauge	.0402"
22 gauge	.0254"

You can see that "hardware store" 22 or 24 gauge wire is very thin. We don't recommend it for any serious audio application. Even 18 gauge "zip cord" (also called "lamp cord") is not that substantial. 16 gauge is our minimum recommendation. 14 gauge is better. 12 gauge is excellent but is comparatively hard to work with (it usually doesn't bend easily and terminations – lugs or banana

plugs – are problematic.) The advantage of large diameter wire is that, all else being equal, it has less resistance to current flow than thin wire.

Speaker Connections

Many Outlaws will use full range speakers with the RR 2150. These speakers reproduce the entire audible range from a single enclosure. Some will augment their full range speakers' bass output capability by adding a subwoofer. In still other cases, some will use compact "monitor" or bookshelf speakers with limited low end performance in combination with a separate subwoofer. Regardless of the configuration, brand or model of your speakers, the RR 2150 is uniquely designed to provide outstanding sound quality.

Physical Connection

The RR 2150 accommodates two separate pairs of speakers so that you may have one pair in your main listening room and another in a remote location such as a patio or the kitchen. Speaker connections are made the same way for both sets of speakers, but always make certain that you connect a pair of speakers, not just one. As the audio sent to both speakers is the same, it makes no difference which pair is connected to which set of terminals, but most will attach their main speakers to the System A terminals and secondary speakers (if used) to the System B terminals.

The speaker connectors (RP19) are five-way connectors with gold-plated contact areas that accept bare wires, pin terminations, "spade" lugs, "eye" lugs, and banana plugs. The choice is yours.

Connecting Loudspeakers to the RR 2150

Speakers A

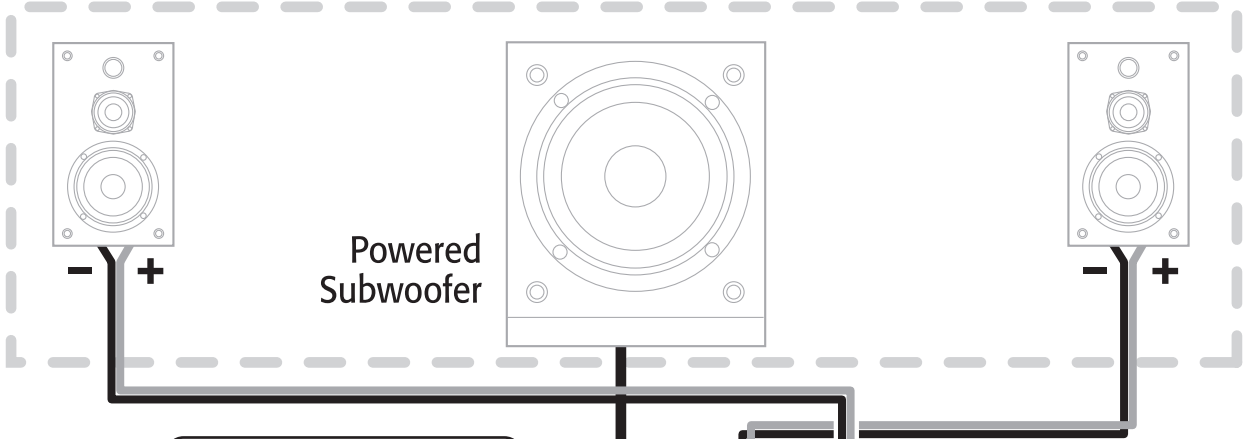

NOTE: Make sure the Pre-out/main-in jumpers are inserted properly.

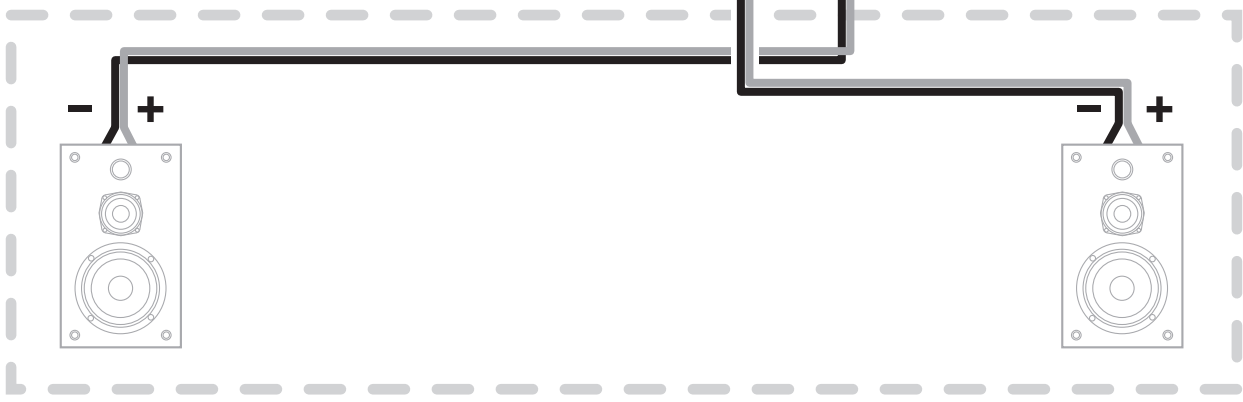
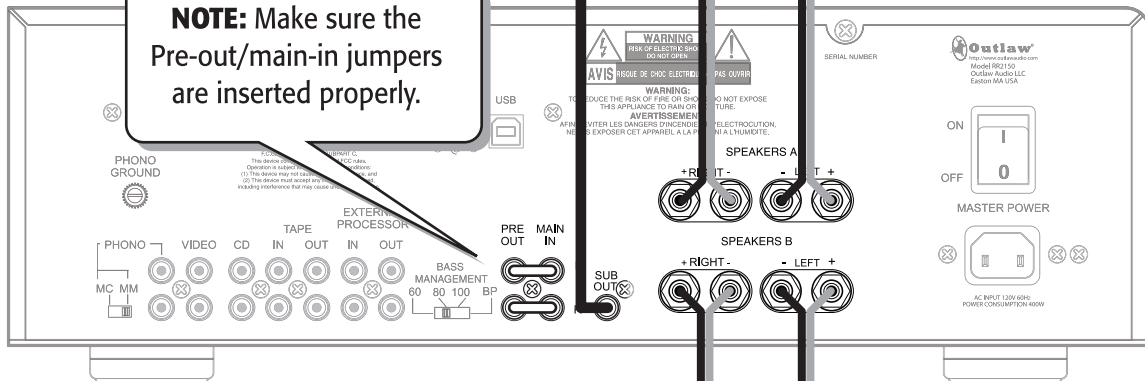

Speakers B

■ Bare wire or pin terminations

Unscrew the outer barrel of the speaker connector until you see the hole in its center post. Insert the conductor or pin into the hole and screw the outer barrel tightly.

● Spade lugs (they look like small two-pronged forks)

Unscrew the barrel enough to place the lug's prongs around the inner post and then retighten the barrel.

● Eye lugs (they are complete circles)

Unscrew the barrel completely until it comes off the post. Place the eye around post, replace the barrel, and tighten.

● Banana plugs

Insert them into the holes in the end of each post/barrel assembly. Just push them in carefully and you're done.

CAUTION: *DO NOT* over tighten the barrels. This isn't a contest of strength. Just hand tighten the barrel enough to insure good contact so that it is snug to the wire or termination device and the speaker terminal.

Whichever type of termination you use, it is important to make sure that the individual wire strands that make up each conductor bundle are tightly wrapped together and that there are no frayed ends that protrude past the speaker terminal or the wire termination for that conductor. This will prevent short circuits and possible amplifier failure.

Remember these three points:

- Make sure to observe proper continuity and polarity.
- For continuity, make sure you connect your main Left speaker to System A's Left terminals and your main Right speaker to the System A's Right terminals. Then connect your secondary speakers to System B terminals, making sure to connect the Left speaker to the Left terminals and the Right speaker to the Right terminals. Care here will save a lot of time later.
- The RR 2150's speaker connections are color-coded. Red terminals are "+" or "hot" while black terminals are "-" or "ground." For proper polarity, make sure that you've connected the proper speaker's "+" terminal (the one with the red barrel) to your speaker's "+" terminal. Then connect the "-" terminal (it has a black barrel) to the same speaker's "-" terminal. It's that simple.

A Note On Phase

When speakers are connected correctly, they are said to be "in phase." This is critical to proper sound reproduction as it means that the drivers in each speaker work together, with the cones in each speaker moving in the same direction at the same time. When speakers are hooked up "out of phase," the drivers in each speaker respond differently to the amplifier's signal. For example, the drivers of the left speaker will push out when the drivers of the right speaker pull in, producing a very imprecise, almost "ghostly," stereo image or poor bass performance. No, there's nothing dangerous about hooking speakers up "out of phase." You won't damage anything, it just doesn't sound good.

Subwoofers and Bass Management Settings

The RR 2150 is unique among stereo receivers in that it has built-in bass management, a feature common, if not required, for multi-channel products, but not found in the two-channel world. While traditional two-channel systems have long used full-range speakers, modern audio systems – even those designed for two-channel music – may use frequency limited bookshelf, or "satellite" speakers in combination with a separate subwoofer.

Bass Management

Rather than provide a simple subwoofer output that places the burden of bass management on the subwoofer, the RR 2150 includes a custom designed analog bass management system that calls upon the heritage of Outlaw's award winning ICBM-1 bass management system for multi-channel systems.

The internal crossover is a symmetrical 2nd order (12 dB/octave) Butterworth filter set. BP (Bypass) duplicates the full range signal sent to your speakers at the subwoofer output. This enables you to utilize the crossover in your subwoofer.

If your system includes a subwoofer, read on for the configuration steps. If you are not using a subwoofer, skip to the next section.

Subwoofers come in two varieties, powered and passive. Powered subwoofers include their own built-in amplifier and are by far the most popular, while passive subwoofers require the use of a separate, external amplifier. You can use either type with your RR 2150.

Powered subwoofers

Use a shielded interconnect cable to connect the RR 2150's subwoofer output jack (RP11F) to the subwoofer's line input jack. If the subwoofer has more than one input jack, check its owner's manual to see which input you should use for a monaural bass signal. Then follow any specific connection and/or configuration instructions supplied with the subwoofer.

We suggest that you use the rear panel Bass Management switch (RP15) rather than your powered sub's internal crossover. You'll find the RR 2150's circuitry exceptionally clean and noise-free compared to similar circuits in most subs.

Passive (non-amplified) subwoofer

Modified "bi-amp" option The modified "bi-amp" configuration uses the RR 2150's internal crossover and is used most often:

Set the RR 2150's Bass Management switch to the crossover frequency (60, 80, or 100 Hz) that is appropriate for your speakers.

Connect the RR 2150's subwoofer output jack (RP18) to the input of the amplifier used to power the subwoofer and the output of the subwoofer amplifier to the subwoofer.

Traditional "bi-amp" option The traditional "bi-amp" configuration requires an external electronics crossover and separate power amplifier:

Set the Bass Management switch (RP15) to BP (bypass). Remove the U-shaped jumpers that connect the RR 2150's preamp outputs (RP16) and power amp inputs (RP17).

Connect the RR 2150's preamp outputs to the crossover's inputs. Connect the crossover's high pass outputs to the RR 2150's main amp inputs. Then connect the crossover's low pass outputs to the inputs of the amplifier you will use to drive your subwoofer and connect that amplifier to the subwoofer.

Adjust the crossover to best integrate the output of the wide range speakers and the subwoofer.

External Amplifier Connections

You can use a separate, external power amplifier either as a substitute for the RR 2150's internal amp or to supplement the internal amp when adding additional speakers in a different area of your home. Remember that the RR 2150 is not designed for "dual source" operation. (Although the "Tape" outputs may be used for that purpose if they are not connected to a recorder.) An additional amplifier will only amplify the source you select with the RR 2150's input selector (FP17 and RC11 for front panel and remote control respectively).

As with any component that is connected to the RR 2150, always make sure that both the RR 2150 and the additional amplifier are OFF or disconnected from any AC power source when making these connections. A misstep here could result in severe damage to your amplifier and/or loudspeakers.

There are a number of options available to connect an external amplifier:

OPTION 1: **Using an external amplifier only.**

Remove the pre-out/main-in U-shaped jumpers. Connect the RR 2150's pre-amplifier outputs (RP17) to the external amplifier's inputs. Next, connect your speakers to the external amplifier.

This option lets you control the volume produced by any speakers connected to the new amplifier with the RR 2150's volume control.

OPTION 2: **Using an external amplifier AND the RR 2150's internal amplifier for two sets of speakers fed with the same source and at the same relative volume level.**

Remove the pre-out/main-in U-shaped jumpers. Using a pair of shielded a "Y" interconnects, connect the RR 2150's left channel preamp output to both the RR 2150's main amplifier inputs and to the left channel inputs of the new amplifier. Repeat the step above for the right channel.

This option lets you control the volume produced by any speakers connected to the new amplifier with the RR 2150's volume control.

OPTION 3: **Using the RR 2150's internal amplifier and external amplifier for two sets of speakers fed with the same source, but with the ability to turn the second pair of speakers on an off from the front panel.**

Do not remove the pre-out/main-in jumpers. Connect the RR 2150's External Loop outputs (RP14) to the external amplifier's inputs. (This, of course, presumes that you are not using the External Loop connections.) Next, connect the speakers to the external amplifier. You will still be able to connect speakers to the RR 2150's amplifier.

The RR 2150's volume control sets the relative level for both pairs of speakers. You may turn the speakers connected to the external amplifier on or off by pressing the External Loop switch on the front panel.

NOTE: This option is best suited for a custom installation and may require a separate volume control for the speakers attached to the external amplifier.

OPTION 4: **Using an external amplifier to send a second source to a second set of speakers.**

Do not remove the pre-out/main-in jumpers. Connect the RR 2150's Tape outputs (RP13) to the external amplifier's inputs. (This, of course, assumes you are not using the Tape connections.) Next, connect the speakers to the external amplifier.

Use the RR 2150's volume control to adjust the level to the speakers connected to the RR 2150.

The input for the source fed to the external amplifier and the speakers connected to it is selected with the front panel Record Selector (FP 18). As the output to the Tape Outputs is fixed, we strongly advise that you either use an amplifier with built-in volume control for this application, or that an optional speaker-level volume control be installed between the outputs of the external amplifier and the speakers. Be certain that the volume control is capable of handling the power output from your external amplifier.

NOTE: As with Option 3, this is best suited for a custom installation to make certain that all external components are properly matched for safe operation.

12 Volt Trigger

The RR 2150 has one 12 volt Trigger output that output offers a 12 volt DC signal that can be used to control compatible external components such as amplifiers, blinds and projection screens.

To control an external device such as an Outlaw power amplifier with the RR 2150, connect the Trigger Output (RP5) on the rear panel to the matching "Trigger" or "Control" input on the external component.

Once the two units are connected, the external component will turn on when the RR 2150 is on, and off when the RR 2150 is turned off.

AC power connection

Insert the supplied power cord into the AC input socket (RP20), and then connect it to a non-switched AC outlet. If a power conditioner or other device is used between the RR 2150 and the AC power source it is your responsibility to make certain that the external device is capable of handling the power drawn by the RR 2150. Use of external power products not compatible with the RR 2150 may create a safety hazard.

It is important use the supplied power cord, not a standard IEC 3-prong (grounded) power cord. If the power cord is replaced, be certain to use one with identical configuration and capacity.

CAUTION: Before you plug the power cord into an AC wall outlet, confirm that you've made all connections to the RR2150 first.

WARNING: Never disconnect the power cord at the RR 2150 end while the other end is still plugged into an AC outlet. This may cause an electric shock. Always connect power by plugging into the AC outlet last and disconnect by unplugging from the AC outlet first.

Connecting an External Amplifier to the RR 2150

Option 1

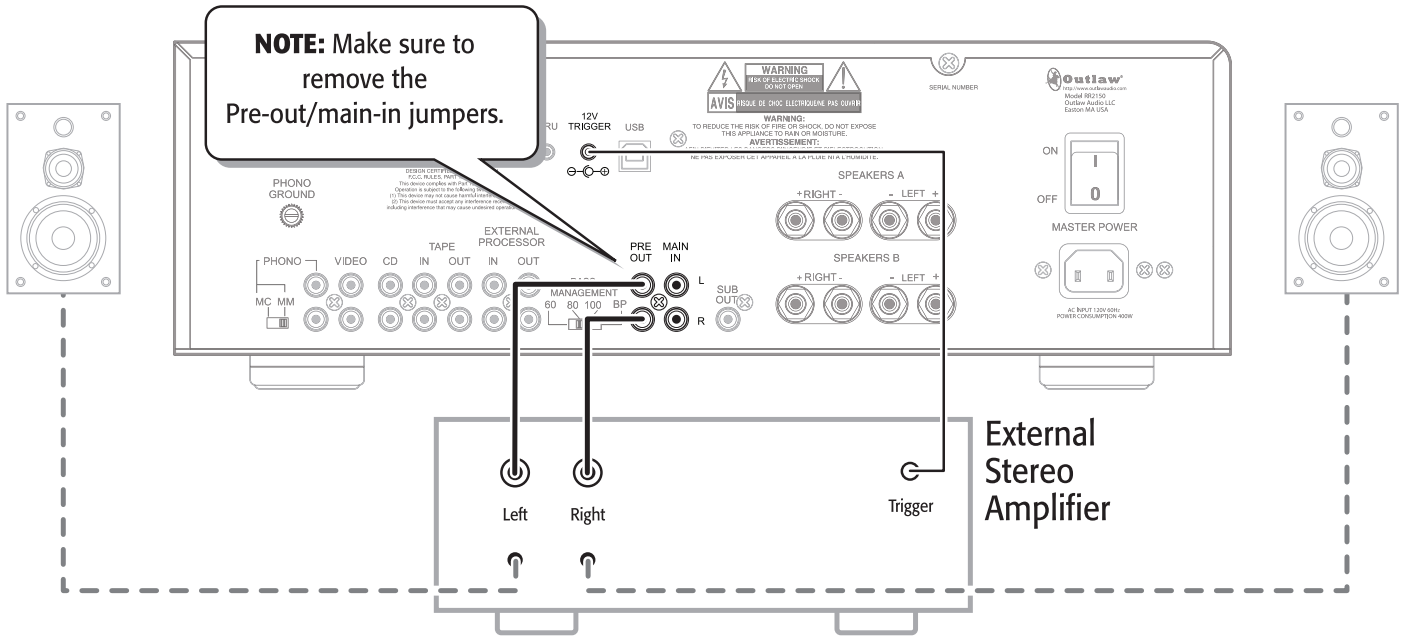

Option 2

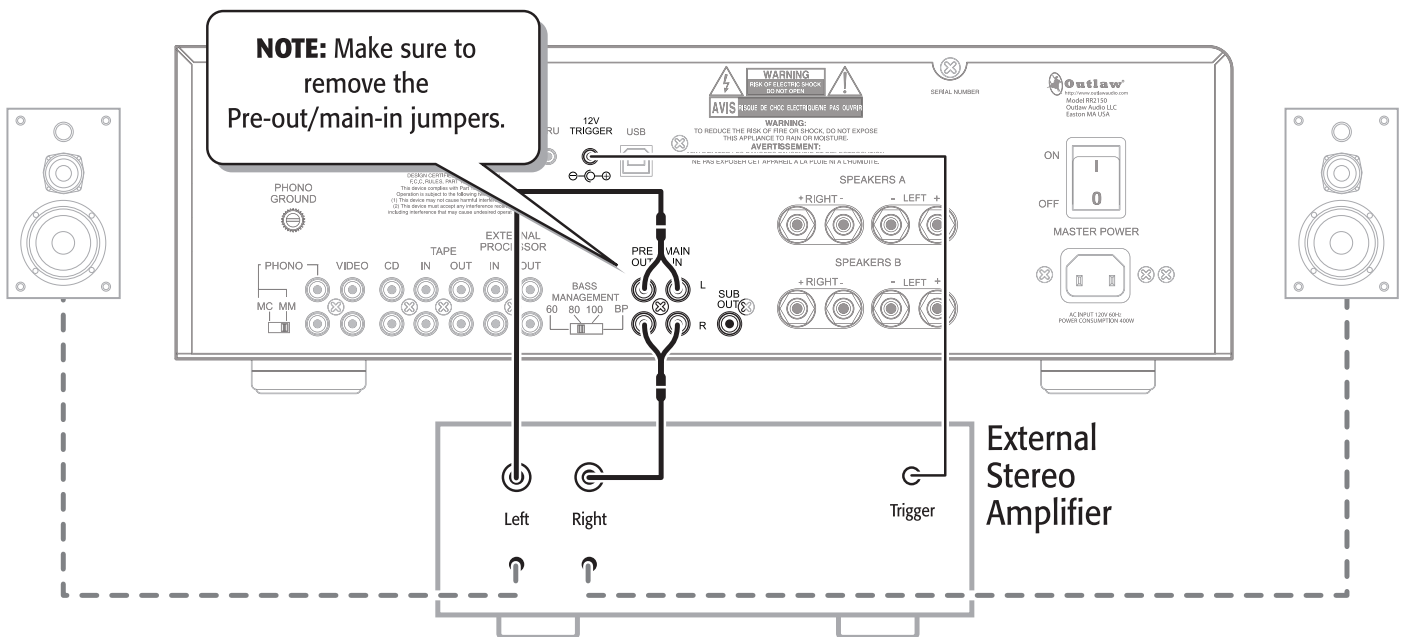

Operation

Once the RR 2150 is connected to sources and speakers, you'll find that it is easy to operate. Read the following section to learn the basics of operating the RR 2150, as well as a few tips and tricks that will enhance your enjoyment of your entire system.

Before using the RR 2150, you'll need to insert the supplied AA batteries into the remote control. Please be sure to match the batteries with the "+" and "-" markings inside the battery compartment during installation.

NOTE: Do not mix new and old batteries or different kinds of batteries. To avoid corrosion, remove the batteries if the remote control will not be used for one month or more. Remove dead batteries immediately to avoid damage from corrosion.

To install batteries in the remote control:

1. On the back of the remote, push the tab and lift off the battery cover.
2. Insert two new AA alkaline batteries. Match the + and - marks on the batteries to the + and - marks in the battery case.
3. Press the battery cover back into place. The tab should click when the cover is locked.
4. Test the unit by pressing any key. If the batteries are inserted correctly, the LED will blink once.

NOTE: The batteries will usually last about six months under normal use. When batteries need replacement, the remote will blink twice with every key press. Simply replace them and the remote control will be restored to its full functionality, including favorite settings.

Power

To turn the RR 2150 on:

1. Turn the rear panel MASTER POWER switch (RP8) on.
The front panel blue Standby LED (FP10) will glow amber.
2. Press the front panel's STANDBY button (FP10) or any source button (RC11) on the remote control.
The Standby indicator will go out and the front panel display will illuminate.

To turn the RR 2150 off:

- Press the front panel's STANDBY button (FP10) or the remote control's PWR button (RC16).
The Standby indicator will turn amber and the front-panel display will turn off.

NOTE: The rear panel Master Power Switch is normally left in the "ON" position, as that enables the unit to be placed in a Standby mode so that it may be turned on or off from the front panel or the remote control. The only times the rear panel switch should be turned off in normal operation is if the RR 2150 will not be used for an extended period of time, or if you wish to connect or disconnect a component or speaker.

Choosing a Source

To select a source from the remote control:

- Press one of the remote control's source buttons (RC11).
The front-panel display will show the selected source. .

To select a source from the front panel:

- Turn the front panel's SOURCE selector button (FP17) to the desired source device.
The front-panel display will show the selected source.

Using the Volume Control

To adjust volume level:

- Press the remote control's VOLUME UP or DOWN buttons (RC5) or turn the front panel's Volume control (FP20).
Holding the remote's Volume Up or Down buttons will turn the level up or down quickly.

Muting the Volume

To Mute the sound off momentarily for a phone call, etc.:

- Press the MUTE button on the front panel (FP19) or the remote control (RC4).
The sound will mute and the front panel Mute button's blue LED will glow.

To turn Muting Off:

- Press the MUTE button to restore volume to its previous level.

Speaker A/B Selection

The RR 2150 allows you to connect two pairs of speakers, each of which will be sent the same output signal. Four options are available, depending on where you set the Speaker Selector Switch (FP14).

- Set the switch to the "A" position to listen to speakers connected to the "A" speaker output terminals only.
- Set the switch to the "B" position to listen to speakers connected to the "B" speaker output terminals only.
- Set the switch to the "A+B" position to listen to both sets of speakers.
- Set the switch to "OFF" to disable all speakers connected to the RR 2150.

Speaker EQ

The RR 2150's unique speaker EQ circuit allows you to add an additional 6dB (about one-half octave) of bass at and below a specific frequency to increase the low end performance of traditional bookshelf speakers. Particularly with sealed (rather than ported) designs with eight or ten inch mid-range drivers, this circuit helps compensate for the roll-off at the low end of the speaker's range. It is not generally recommended for use when a separate subwoofer is connected.

It is important to understand that this circuit is not a replacement for the traditional "Bass Control", which applies boost or cut across the entire spectrum. Further, this circuit is not part of the bass management circuit, described on page 15.

To activate Speaker EQ:

1. Look at the specification for your speakers and check for the lowest frequency your speakers are able to reproduce.
2. Turn the SPEAKER EQ switch (FP15) to the frequency that is either at that frequency, or one notch above it.

There is no hard rule as to which way to set this, if indeed you feel it contributes to the sound of your system at all. A variety of conditions, including the type of speakers in use, the room acoustics and your personal listening preferences are all factors here. If you like the way the system sounds, choose the setting that works best for you.

To activate Speaker EQ:

- Set the SPEAKER EQ (FP15) switch to OFF.

NOTE: Be careful about using this circuit when the bass control is turned to its maximum boost. That is almost guaranteed to provide an undesirable result!

Adjusting Tone Controls

The RR 2150 offers front panel tone controls that may be adjusted to suit your listening taste. You may also take the tone controls out of the circuit completely for “flat” operation.

To adjust the Tone controls:

1. Press the TONE OFF button (FP1) so that the button's blue LED is off.

This activates the tone control circuitry.

2. Turn the BASS control knob (FP2) clockwise or counterclockwise.

You can adjust the bass cut or boost within a range of ± 6 dB. The center detent represents the setting where bass is neither added or removed.

3. Turn the TREBLE control knob (FP5) clockwise or counterclockwise.

You can adjust the treble cut or boost within a range of ± 6 dB. The center detent represents the setting where treble is neither added or removed.

To disable the Tone controls:

- Press the TONE OFF button (FP1)

The button's blue LED will light to remind you that the tone controls are deactivated.

Balance Adjustment

The left/right balance of the RR 2150's output may be adjusted by using the Balance Control.

To adjust the balance:

- Turn the BALANCE control knob (FP3) clockwise or counterclockwise.

Turning the knob clockwise emphasizes the right speaker more. Turning the knob counterclockwise emphasizes the left speaker.

Using Headphones

You can use headphones for private listening without disturbing others or for critical listening. Be aware that the headphone experience is not the same as using speakers. Although some listeners prefer headphones, most prefer the loudspeaker experience better. It's your choice.

To listen to the RR 2150 using headphones:

1. Plug in any pair of headphones using a standard 1/4 inch stereo headphone jack into the front panel input (F11).

For headphones used with portable devices, you may need a 3.5mm to 1/4 inch adaptor available at most electronics parts stores.

2. Use the HEADPHONE LEVEL (FP12) control to the right of the headphone jack to set the sound level for the headphones.

3. Use the BALANCE (FP3), BASS (FP2) and TREBLE (FP5) controls to adjust the sound output of the headphones.

NOTE: The RR 2150's volume control also affects headphone output. So, if you want a truly private headphone experience, turn the Speaker selector (FP14) off.

Recording

The RR 2150 allows you to send the signal from any input source to a recording device properly connected to the rear panel Tape jacks (RP13). Note that unlike many current audio products, the RR 2150 has a separate record output bus so that you may listen to one source (selected with the remote control or the front panel Source control) and record a different source. It is important to remember this, as you may be used to always having the source you are listening to being sent to the record output.

To record from a selected input source:

1. Prepare your recording device.

Follow the recommended procedure from the recorder manufacturer about input settings, levels etc.

2. Select the source you want to record by using the front panel RECORD selector (FP18).

3. Place the device in record mode to begin recording.

To monitor your recording:

- Set the SOURCE selector (FP17) to your recording device.

Audio from your recording device will play through the RR 2150.

To listen to another source during recording:

- Set the SOURCE selector (FP17) to the desired input source.

Audio from the selected source will play through the RR 2150. Audio to the recording will not be affected.

Setting Sleep Timer

The RR 2150's sleep timer automatically shuts the unit off after a predetermined amount of time.

To activate the sleep timer:

1. Press the remote control's SLEEP button (RC6).

The front panel display will show "Sleep" and the number of minutes until the unit shuts off immediately below the word "Sleep."

2. Press the SLEEP button repeatedly until you've chosen the amount of "sleep time" you want.

The available choices are:

75MIN→60MIN→45MIN→30MIN→20MIN→15MIN→10MIN→5MIN→OFF

Using the AM/FM Tuner

The RR 2150's AM/FM/FM stereo is exceptionally flexible and user-friendly. It is, however, the only source that must be set up to match your listening preferences. Once you've followed the simple steps shown in the following pages, you'll be able to easily enjoy your favorite AM, FM, and FM stereo broadcasts.

Selecting Tuner Mode

To select the tuner from the front panel:

1. Turn the SOURCE Selector (FP17) until the desired band (AM or FM) appears in the front panel display.
2. Using the UP and DOWN tuning buttons (FP6 and FP7 respectively), tune to the station you want to listen to.

To select the tuner from the remote control:

1. Press the RR device control button (RC2) on the remote control.
2. Press the AM/FM button (RC12) until the desired band appears in the front panel display.
3. Press the CHANNEL UP and DOWN buttons (RC18 and RC19) to select the desired station.

To select AM or FM when the tuner is already in use with the Source selector:

- Turn the SOURCE selector (FP17) until the correct band appears in the front panel display.

To select AM or FM when the tuner is already in use with the Function button:

1. Press the FUNCTION button on the front panel (FP8) or the remote control (RC21) once.

"Band" appears in the front panel display, the Function button's blue LED lights and the Enter button's red LED blinks.

2. Press ENTER on the front panel (FP9) or the remote control (RC17).

The red LED on the Enter button will go out and the blue LED on the Function button will continue to glow.

3. Use the UP or DOWN tuning button on the front panel (FP6/FP7) or on the remote control (RC18/RC19) until you've made your choice.

The selected band appears in the front panel display.

4. Press ENTER again.

The blue LED on the Function button will extinguish.

Obviously, using the Source selector is far easier and you'll probably use this method most of the time. The reason we began with the Function button is that it lets you access other benefits, as described below.

Tuning a Station and The Tuning Mode

The RR 2150's Tune Mode function lets you choose between Manual and Auto tuning modes.

Manual Tuning This mode uses the Up or Down tuning buttons to take you to the next lower or higher frequency regardless of whether or not that frequency carries a broadcast. In this mode, FM stations are tuned regardless of whether the broadcast is mono or stereo.

Auto Tuning This mode uses the Up or Down tuning buttons to advance to the next higher (or lower) frequency in the band you've selected that has a signal strong enough for acceptable reception. In this mode only FM stations broadcasting stereo signals are tuned.

To select the desired tuning mode using the Function button:

1. Press the FUNCTION button on the front panel (FP8) or the remote control (RC21) twice.

"T MODE" appears in the front panel display, the Function button's blue LED lights and the Enter button's red LED blinks.

2. Press ENTER on the front panel (FP9) or the remote control (RC17).

The red LED on the Enter button will go out and the blue LED on the Function button will continue to glow.

3. Use the UP or DOWN tuning button on the front panel (FP6/FP7) or the remote control (RC18/RC19) to toggle between the two modes.

The word "Auto" will appear in the front panel display above "T Mode" when Auto tuning is selected. The display will remain blank if Manual tuning is selected.

4. Press the ENTER button again.

The front panel display will show the currently tuned broadcast frequency.

FM Tuner Mode

To change the FM tuner mode (mono or stereo):

- Press TUNER MODE on the remote control (RC13) to select the desired tuner mode.

STEREO will tune stereo signals.

MONO will tune either mono or stereo signals. When a station's signal is weak in the STEREO mode, selecting mono will often provide a signal that is more acceptable by switching to the mono sound mode.

Direct Tuning

You may tune up or down through the AM or FM bands using the Up/Down tuning controls on the front panel or remote, but sometimes you may wish to tune a station directly. That is easy to do on the RR 2150 by following these steps:

Once you've entered the complete frequency, the tuner will automatically tune to it

To enter a frequency (station) directly:

1. Press **DIRECT** on the remote control (RC19).
The current frequency will go blank on the front panel display.
2. Use the 10 numeric keys on the remote control (RC3) to enter the desired frequency.
For example, to enter 89.3 FM, simply punch in 893. The numbers will appear on the front panel display as you key them in.
The tuner will automatically tune to the new frequency.

Memorizing Your Favorite Stations

Once you have tuned to a station, you may enter it into the RR 2150's memory so that it may be easily recalled for future listening. The tuner memory holds up to 39 stations in any order you choose – it even intermixes FM and AM frequencies.

NOTE: Although you can use the front panel controls to program your favorite stations, we suggest that you use the remote control as it is more convenient. Using the front panel controls may result in the internal microprocessor picking an arbitrary preset number that you might find inconvenient or confusing.

To program stations into memory using the remote control:

1. Tune to the AM or FM station you want the RR 2150 to memorize.
2. Press the **MEMORY** button on the remote control (RC27).
"MEM" will appear in the front panel display in small orange letters immediately above the chosen frequency.
If any station presets have already been entered, you'll see a number immediately below the word "PRESET" in the front panel display.
3. Within 5 seconds, enter a two-digit memory number (from 01 to 39) using the remote control's numeric keypad (RC3).
The word "PRESET" will appear above and to the right of the frequency readout and the number of that preset will appear directly below.
If a station preset already existed, it is replaced by the new number.
4. Repeat these steps for any additional stations, up to a total of 39.

To program stations into memory using the Function button:

1. Press the **FUNCTION** button on the front panel (FP17) or remote control (RC21) as many times as needed until "MEM," "PRESET" and a preset number appear in the front panel display.
The blue LED in the Function button will light and the red LED in the Enter button will blink.
2. Press **ENTER** on the front panel (FP9) or the remote control (RC17).
"MEM" will blink in the front panel display.
3. Press **ENTER** again to accept the current preset number.

OR

- Press the **UP** or **DOWN** buttons on the front panel (FP6/FP7) or remote control (RC 18/RC19) until the desired number appears.
4. Within 5 seconds, press the **ENTER** button to memorize the new station preset number.

Tuning a Preset Station

Once a station's frequency is entered into the RR 2150's memory, it is easy to recall the station or scan through the list of preset stations.

To select a preset station:

- With tuner selected as your source, enter the two digit preset number of the desired station using the 10 numeric keys on the remote control (RC3).

Preset Tune

You manually tune to the stations you've already programmed into the RR 2150's memory. You may do this from either the remote or the front panel.

To manually scan through your preset stations:

- With tuner selected as your source, press the **PRESET UP** or **PRESET DOWN** buttons on the remote control (RC23 and RC24) until the desired station is heard.

OR

1. Press the **FUNCTION** button on the front panel (FP8) or remote control ((RC21) until "P TUNE" appears in the front panel display.
The blue LED of the Function button's lights. The red LED of the Enter button blinks.
2. Press **ENTER** on the front panel (FP9) or the remote control (RC17).
The red LED of the Enter button will go out. The blue LED of the Function button will continue to glow.
3. Press either the **UP** or **DOWN** buttons on the front panel (FP6/FP7) or remote control (RC18/RC19) to scroll through the list of preset stations.

Preset Scan

When you don't remember exactly which preset station you want to listen to and don't want to go to the trouble of manually tuning in all your presets, you can let the RR 2150 do it for you by automatically scanning your favorite stations.

To automatically scan your preset stations using the P.Scan button:

1. With tuner selected as your source, press the **P.SCAN** button on the remote control (RC24).
The tuner will scan up through the list of stations, stopping at each one for five seconds.
2. Press the **P.SCAN** button again when the desired station is playing.

To automatically scan through your preset stations using the Function button:

1. Press the **FUNCTION** button on the front panel (FP8) or remote control (RC21) until "P SCAN" appears in the front panel display.
The blue LED of the Function button's lights. The red LED of the Enter button blinks.
2. Press **ENTER** on the front panel (FP9) or the remote control (RC17).
The red LED on the Enter button will go out. The blue LED on the Function button will continue to glow.
The RR 2150 will begin to scan your presets, stopping at each memorized station for five seconds.
3. Press the **ENTER** button again when you reach the desired preset.

Programming the Remote Control

In addition to the RR 2150 itself, the remote control can operate up to three other devices, and is preprogrammed with command codes for hundreds of components.

To program your remote for another device, you will first input a single digit device code, followed by a four-digit code from the table in the following pages. Before you start that process, here are some things you need to be aware of:

- More than one setup code number may work with a source component. Test the functions for each of the code numbers that work to determine the best one for your particular unit.
- Some components (CD and DVD players, for example) do not have power buttons on their original remote controls and thus may not turn on or off as you expect. If you run into problems, first store the setup code number and then test functions (Play, Stop, etc.) to determine if you've selected the correct number.

Setup Using Preprogrammed Codes

To program the remote control using four-digit codes:

1. Turn on the device (TV, VCR, cable box) you would like the remote control to operate.

Do this manually or with the device's original remote control.

2. Find the four-digit setup code number for your device.

The tables of four-digit codes can be found on pages 24 to 26.

3. On the RR 2150 remote control, press the proper device selector button (RC2) that corresponds to the device you want to control.

Remember that the RR button is used exclusively for the RR 2150.

4. Press and hold the RR 2150 remote control's SETUP button (RC1).

The red LED at the top of the remote control (RC15) blinks twice.

5. Release the SETUP button.

6. Enter the single-digit device code for your component using the numeric keys on the remote control (RC3).

Press "0" if you are programming a Cable or Satellite box.

Press "1" if you are programming a Television.

Press "2" if you are programming a VCR or DVD player.

Press "3" if you are programming a CD player.

7. Enter the first four-digit code for your component using the numeric keys on the remote control (RC3).

The LED should blink twice. If it does not, repeat the steps above using the same code.

8. Aim the remote control at the component and press the PWR button (RC16) once.

The component should turn off. If it doesn't respond, repeat steps 4-7 above using the other codes for your brand until you find one that works.

If none of the codes work, try searching for the code (see "Searching For Your Code," below).

9. Repeat the process for other components you wish to control with the RR 2150 remote control.

Searching for Unknown Codes

If your device does not respond to the remote after you have tried all codes listed for your brand, or if your brand is not listed at all, you can try searching for the code.

To search for a code for your component:

1. Press the Device Control Selector button (RC2) on the remote control that corresponds to the device you want to control.

Remember that the RR button is used exclusively for the RR 2150.

2. Press and hold the RR 2150 remote control's SETUP button (RC1).

The red LED at the top of the remote control (RC15) blinks twice.

3. Release the SETUP button.

4. Enter 990 using the numeric keys on the remote control (RC3).

The LED will blink twice.

5. To determine the first number in the code sequence, aim the remote control at the component and press 1 on the numeric keypad (RC3) of the RR 2150 remote control.

After three seconds, the LED will blink to indicate that number: i.e., 1 blink = 1, 2 blinks = 2, and so on. Note that no blink indicates the number zero (0).

6. Count the blinks and write down the number.

7. Repeat step for each of the other four digits: Press 2 for the second digit, 3 for the third, 4 for the fourth, and 5 for the fifth.

8. Use the resulting five-digit code (1 digit device code and 4 digit program code) to program the RR 2150 remote control to operate the device according to steps 3-8 in the previous section "Setup Using Preprogrammed Codes."

9. Repeat these steps, but substitute the appropriate device button, for the next component you are checking.

Some General Comments on Using Your Remote

For best remote control performance, please follow these guidelines:

- Remember to point the remote control toward the remote control sensor on the RR 2150, not toward the TV screen.
- Place the 2150 away from strong light such as direct sunlight or fluorescent light, which can interfere with the infrared pulses generated by the remote control.
- Using another remote control of a similar type or placing the RR 2150 near equipment which also uses infrared control may cause interference and intermittent operation.
- Do not put anything (other than your hands, of course) on the remote control. If the buttons are continuously pressed by mistake, you'll probably drain the batteries.
- If you put your RR 2150 in a closet or behind wood or smoked/colored glass doors, you'll probably have to mount an infrared sensor outside the cabinet or closet and connect the sensor to the RR 2150's rear panel IR input (RP2A).
- If there's an obstacle between the remote control and the front panel remote control sensor, the remote control will not operate. Remember that IR (infrared) is primarily a "line of sight" control mechanism.

Care and Maintenance

Cleaning

To clean normal dust, wipe your RR 2150 with a clean, soft, dry cloth.

If the dirt has really accumulated (Outlaws aren't always the most meticulous people, are they?), first wipe the surface with a soft cloth that's slightly dampened with mild soapy water. Follow that with a fresh cloth dampened with clean water. Wipe dry immediately!

NEVER use benzene, thinner, alcohol or any other volatile cleaning agent. Do not use abrasive cleaners, as they may damage the finish of the metal parts.

Avoid spraying insecticide, waxes, polishing agents, or any aerosol product near the unit.

When You're Away

If you will not be using your home theater system for an extended period of time, it's always a good idea to turn everything off.

For the RR 2150, this means unlatching the rear panel's Master Power switch (RP8). This will prevent the automatic turn on circuits from accidentally turning the system on during your absence.

You may want to unplug all your other components, too.

If you think there's a possibility of electrical storms during your absence, it's also a very good idea to disconnect all "downleads" (cable and satellite antenna connections, etc.) to prevent high voltage spikes that may damage your components.

Troubleshooting

Your new RR 2150 is designed to provide years of trouble-free operation. However, the complexity of today's sophisticated home theater systems means that you might encounter an occasional problem with your system. You'll find some of the more common issues listed below.

You can also look at the RR 2150 section of our website (www.outlawaudio.com), or enter the RR 2150 Section of our Outlaw Saloon. If your problem persists, please call us at **866-OUTLAWS** (688-5297) or **866-OUTLAWA** (688-5292).

Symptom	Possible Cause	Solution Options
Unit does not turn on when remote or front panel buttons are pressed	No AC Power	Make certain AC power cord is plugged into a live outlet Make certain rear panel MAIN POWER switch is ON
Intermittent buzzing in tuner	Interference from local sources	Move or relocate the antenna Move the antenna or unit away from computers, fluorescent or neon lights, or appliances with motors
Unit does not respond to remote commands	Low remote battery power Remote set to different device Remote sensor is obscured	Change the batteries Press the RR button to make sure the remote is outputting RR 2150 codes Make certain the front-panel remote sensor is not blocked or connect an external remote sensor
No sound from one or both channels	Poor connections Incorrect speaker mode	Check interconnects to the amplifier and speakers Check speaker selector to make sure connected speakers are turned on.

Setup Codes

CABLE CONVERTERS

<i>Manufacturer/Brand</i>	<i>Setup Code Number</i>
ABC	0003, 0017
Americast	0899
Bell South	0899
General Instrument	0276, 0476, 0810
GoldStar	0144
Hamlin	0009, 0273
Jerrold	0003, 0276, 0476, 0810
Memorex	0000
Motorola	1106
Pace	0237
Panasonic	0107, 0000
Paragon	0000
Philips	0305, 0317
Pioneer	0144, 0533, 0877
Pulsar	0000
Quasar	0000
Regal	0273, 0279
Bunco	0000
Samsung	0144
Scientific Atlanta	0017, 0477, 0877
Starcom	0003
Toshiba	0000
Zenith	0000, 0525, 0899

CD PLAYERS

<i>Manufacturer/Brand</i>	<i>Setup Code Number</i>
Aiwa	0157
Burmester	0420
Cal. Audio Labs	0029
Carver	0157, 0179
DKK	0000
Demon	0003, 0873
Emerson	0305
Fisher	0179
Garrard	0420
Genexxa	0032, 0305
Harman/Kardon	0157, 0173
Hitachi	0032
JVC	0072
Kenwood	0028, 0190, 0826, 0037, 0626, 0681
Krell	0157
LX.	0305

Linn	0157
MCS	0029
MTC	0420
Magnavox	0157, 0305
Marantz	0157, 0626, 0029
Mission	0157
NSM	0157
Onkyo	0101, 0868
Optimus	0032, 0468, 0420, 0179, 0305, 1063, 0000, 0037, 0145
Panasonic	0029
Parasound	0420
Philips	0157, 0626
Pioneer	0032, 0468, 0305, 1062, 1063
Polk Audio	0157
Proton	0157
QED	0157
Quasar	0029
RCA	0053, 0032, 1062, 0468, 0305, 0179
Realistic	0179, 0420
Rotel	0157, 0420
SAE	0157
Sansui	0157, 0305
Sanyo	0179
Scott	0305
Sears	0305
Sharp	0037, 0861
Sherwood	1067
Sonic Frontiers	0157
Sony	0000, 0490
Soundesign	0145
Tascam	0420
Teac	0420
Technics	0029
Victor	0072
Wards	0053, 0157
Yamaha	0036, 0888

DVD PLAYERS

<i>Manufacturer/Brand</i>	<i>Setup Code Number</i>
Apex	0672
Denon	0490
Fisher	0670
GE	0522
Gradiente	0651
Hitachi	0573, 0664

Hiteker	0672
JVC	0623, 0558
Kenwood	0682, 0534
Konka	0719, 0711, 0720, 0721
Magnavox	0503, 0675
Marantz	0539
Mitsubishi	0521
Onkyo	0503
Optimus	0571
Oritron	0651
Panasonic	0490, 0677, 0632
Philips	0539, 0503
Pioneer	0571, 0525, 0632
Proscan	0522
RCA	0522, 0571
Samsung	0573
Sharp	0630
Sony	0533
Toshiba	0503
Yamaha	0490, 0545
Zenith	0591, 0503

SATELLITE RECEIVERS

<i>Manufacturer/Brand</i>	<i>Setup Code Number</i>
AlphaStar	0772
Chaparral	0216
Echostar	0775, 1005
GE	0566
General Instrument	0869
HTS	0775
Hughes Net. Sys.	0749, 1142, 1749
Philips	1076, 1142, 0722, 0724, 0749
Proscan	0392
RCA	0506, 0392, 0143, 0855
Radio Shack	0869
Samsung	1109
Star Choice	0869
Zenith	0856

VIDEO ACCESSORIES

<i>Manufacturer/Brand</i>	<i>Setup Code Number</i>
Panasonic	1120
Pioneer	1010
Sensory Science	1126
Sharp	1010

TELEVISIONS

<i>Manufacturer/Brand</i>	<i>Setup Code Number</i>
AOC	0019, 0030
Admiral	0093, 0463
Aiko	0092
Aiwa	0701
Akai	0030
Alaron	0179
America Action	0180
Anam	0180
Audiovox	0092, 0180, 0451, 0623
Baysonic	0180
Bclmr	0019
Bell & Howell	0016, 0154
Bradford	0180
Brockwood	0019
Broksonic	0236, 0463
CXC	0180
Candle	0030, 0056
Carnivale	0030
Carver	0054
Celebrity	0000
Cineral	0451, 0092
Citizen	0056, 0030, 0060, 0092
Concerto	0056
Contec	0180
Craig	0180
Crosley	0054
Crown	0180
Curtis Mathes	0060, 0030, 0016, 0047, 0051, 0054, 0056, 0093, 0145, 0154, 0166, 0451, 1147, 1347
Daewoo	0092, 0623, 0019, 0624, 0451
Daytron	0019
Denon	0145
Dumont	0017, 0019
Electroband	0000
Emerson	0236, 0180, 0178, 0179, 0463, 0624, 0623, 0019, 0154
Envision	0030
Fisher	0154
Fujitsu	0179, 0683
Funai	0180, 0171, 0179
Futuretech	0180
GE	0047, 1347, 0051, 0178, 0451, 1147, 0093
Gibraltar	0017, 0019, 0030
GoldStar	0178, 0019, 0030, 0056

Gradiente	0056, 0053
Grunpy	0179, 0180
Hallmark	0178
Harley Davidson	0179
Harman/Kardon	0054
Harvard	0180
Hitachi	0145, 0056, 0016
Infinity	0054
Inteq	0017
JBL	0054
JCB	0000
KEC	0180
KTV	0180, 0030
Kenwood	0030, 0019
Konka	0707, 0632, 0628, 0638, 0703
LG	0056
LXI	0154, 0047, 0054, 0156, 0178
Logik	0016
Luxman	0056
MGA	0150, 0019, 0030, 0178
MTC	0060, 0030, 0019, 0056
Magnavox	0054, 0030, 0179, 1254
Marantz	0054, 0030
Matsushita	0250
Megatron	0145, 0178
Memorex	0179, 0463, 0178, 0016, 0056, 0150, 0154, 0250
Midland	0017, 0047, 0051
Motorola	0093
Multitech	0180
NAD	0156, 0166, 0178
NEC	0030, 0019, 0056
NTC	0092
Nikko	0178, 0030, 0092
Onwa	0180
Optimus	0250, 0166, 0154
Optonica	0093
Orion	0463, 0179, 0236
Panasonic	0051, 0250
Penney	0047, 1347, 0060, 0030, 0178, 0051, 0019, 0056, 0156
Philco	0145, 0019, 0030, 0054, 0463
Philips	0054
Pilot	0019, 0030
Pioneer	0166, 0679
Portland	0019, 0092
Princeton	0717

Prism	0051
Proscan	0047
Proton	0178
Pulsar	0017, 0019
Quasar	0051, 0250
RCA	0047, 1347, 1147, 0679, 1247, 0019, 0051, 0090, 0093, 1047, 1447
RadloShack	0180, 0030, 0178, 0154, 0019, 0047, 0056
Realistic	0180, 0154, 0030, 0178, 0019, 0056
Runco	0017, 0030
SSS	0019, 0180
Sampo	0030
Samsung	0060, 0019, 0178, 0030, 0056
Sansei	0451
Sansui	0463
Sanyo	0154
Scimitsu	0019
Scotch	0178
Scott	0236, 0019, 0178, 0179, 0180
Sears	0154, 0056, 0156, 0047, 0054, 0171, 0178, 0179
Semivox	0180
Setup	0156
Sharp	0093, 0688
Shogun	0019
Signature	0016
Sony	0000
Soundesign	0178, 0179, 0180
Squareview	0171
Starlite	0180
Supreme	0000
Sylvania	0054, 0030
Symphonic	0171, 0180
TMK	0056, 0178
TNC	0017
Tandy	0093
Technics	0051, 0250
TechnoAce	0179
Techwood	0051, 0056
Teknika	0016, 0054, 0179, 0180, 0 019, 0092, 0056, 0060, 0150
Telefunken	0056
Toshiba	0156, 0060, 0154, 1256
Vector Research	0030
Victor	0053

Vidikron	0054
Vidtech	0019, 0178
Wards	0054, 0178, 0016, 0019, 0030, 0056, 0179
White Westinghouse	0624, 0623, 0463
Yamaha	0019, 0030
Zenith	0017, 0624, 0016, 0092, 0463
VCRs	
<i>Manufacturer/Brand</i>	<i>Setup Code Number</i>
Admiral	0048, 0209
Adventure	0000
Aiko	0278
Aiwa	0000, 0037
Asha	0240
Audiovox	0037
Beaumarck	0240
Bell & Howell	0104
Broksonic	0121, 0184, 0002, 0209, 0479
CCE	0072, 0278
Calix	0037
Canon	0035
Carver	0081
Citizen	0278, 0037
Colt	0072
Craig	0037, 0072, 0047, 0240
Curtis Mathes	0035, 0060, 0162
Cybernex	0240
Daewoo	0278, 0045
Denon	0042
Dynatech	0000
Electrohome	0037
Electrophonic	0037
Emerex	0032
Emerson	0184, 0002, 0209, 0278, 0121, 0479, 0000, 0037, 0043
Fisher	0047, 0104
Fuji	0033, 0035
Funai	0000
GE	0035, 0060, 0048, 0240
Garrard	0000
Go Video	0432
GoldStar	0037, 0038
Gradiente	0000
HI-Q	0047
Harley Davidson	0000
Harman/Kardon	0038, 0081
Harwood	0072

Hitachi	0042, 0000
Hughes Net. Sys.	0042
JVC	0067
KEC	0037, 0278
KLH	0072
Kenwood	0067, 0038
Kodak	0035, 0037
LXI	0037
Lloyd's	0000
Logik	0072
MEI	0035
MGA	0043, 0240
MGN Technology	0240
MTC	0000, 0240
Magnasonic	0278
Magnavox	0035, 0081, 0563, 0000, 0039, 0149
Marantz	0081, 0035
Marta	0037
Matsushita	0035, 0162
Memorex	0104, 0047, 0479, 0000, 0037, 0048, 0035, 0240, 1037, 0039, 0162, 0209, 1162, 1262
Minolta	0042
Mitsubishi	0043, 0048, 0067
Motorola	0035, 0048
Multitech	0000, 0072
NEC	0038, 0067, 0104
Nikko	0037
Noblex	0240
Olympus	0035
Optimus	0162, 1062, 1162, 0048, 1262, 0037, 1048, 0104, 0432
Orion	0479, 0002, 0184, 0209
Panasonic	0035, 0162, 1162, 1262, 1362, 0616, 1062
Penney	0035, 0240, 0037, 0042, 0038
Pentax	0042
Philco	0035, 0209, 0479
Philips	0081, 0035, 0618, 1081, 1181
Pilot	0037
Pioneer	0067
Polk Audio	0081
Profitronic	0240
Proscan	0060
Protec	0072
Pulsar	0039
Quasar	0035, 0162, 1162

RCA	0060
RadioShack	0000, 1037
Radix	0037
Randex	0037
Realistic	0000, 0104, 0047, 0048, 0037, 0035
ReplayTV	0614, 0616
Runco	0039
STS	0042
Samsung	0045, 0240
Sansui	0479, 0000, 0067, 0209
Sanyo	0047, 0104, 0240
Scott	0184, 0121, 0043, 0045
Sears	0037, 0042, 0000, 0035, 0047, 0104
Semp	0045
Sharp	0048
Shintom	0072
Shogun	0240
Singer	0072
Sony	0033, 0032, 0000, 0035, 0636, 1032
Sylvania	0035, 0081, 0000, 0043
Symphonic	0000
TMK	0240
Teac	0000
Technics	0035, 0162
Teknika	0000, 0035, 0037
Thomas	0000
Tivo	0618, 0636
Toshiba	0045, 0043
Totevision	0037, 0240
Unitech	0240
Vector	0045
Vector Research	0038
Video Concepts	0045
Videosonic	0240
Wards	0035, 0060, 0000, 0047, 0240, 0042, 0048, 0072, 0081, 0149
White Westinghouse	0072, 0278, 0209
XR-1000	0072, 0000, 0035
Yamaha	0038
Zenith	0039, 0000, 0033, 0209, 0479

RR 2150 Specifications

Audio Section

Continuous Average Power both channels driven	100 Watts/channel (8 Ω , 20Hz to 20kHz, <0.03% THD) 160 Watts/channel (4 Ω , 20Hz to 20kHz, <0.03% THD)
Input Sensitivity/Impedance	
High Level	200mV/47k Ω
MM Phono	3.3mV/47k Ω
MC Phono	0.6mV/47k Ω
Bass Management	
High-Pass Slope	Adjustable 60Hz/80Hz/100Hz/Bypass 12 dB/octave (2nd order)
Low-Pass Slope	12dB/octave (2nd order)
Tone Control	
Bass Center Frequency/Range	50Hz \pm 6.5dB
Treble Center Frequency/Range	1KHz \pm 6.5db
Frequency Response @ 1W	20Hz to 20kHz (+ 0dB/- 0.5dB)
S/N Ratio (IHF-A)	96dB unweighted
Transient IMD	Unmeasurable

FM Tuner Section

Frequency Range	87.5 – 108MHz
Usable Sensitivity (IHF)	12dBf
S/N Ratio	
Mono	75dB
Stereo	70dB
Stereo Distortion	0.24%
Stereo Separation @ 19kHz	37dB
Selectivity	70dB \pm 10kHz

AM Tuner Section

Frequency Range	530 – 1710kHz
Usable Sensitivity	500 μ V/M
S/N Ratio	>54dB
Selectivity	>25dB \pm 10kHz

General

Supply Voltage	120V, 60Hz only
Power Consumption	
Idle	5W
@ Full Load	400W max.
Trigger Output	Sequential Delay 50 mA @ 12 VDC
Dimensions (W x H x D)	17.1 x 5.75 x 15.0 inches
Weight	27 lbs.

All features and specifications are subject to change without notice or liability to upgrade existing units.

Outlaw Audio and the Outlaw Audio logo are registered trademarks of Outlaw Audio, LLC.

Any trademark not acknowledged is recognized as the property of the respective owner.

Outlaw Audio Limited Warranty

This warranty protects the owner of the Outlaw RR 2150 Stereo RetroReceiver (the PRODUCT) for two (2) years from the date of purchase and covers defects in material and workmanship with the following specific exceptions. These are:

- Damage caused by improper installation or adjustment
- Damage caused by accident, unreasonable use or neglect
- Damage from failure to follow instructions contained in this Owner's Manual
- Damage from the performance of repairs by someone not authorized by Outlaw Audio
- Any unit on which the serial number has been effaced, modified, or removed
- Damage occurring during shipment
- Units which have been altered or modified in design, appearance or construction.

This warranty covers only the actual defects within the PRODUCT itself. IT DOES NOT cover costs of installation in (or removal from) a fixed installation, or normal setup, claims based on any misrepresentation by the seller, or performance variations resulting from installation related circumstances such as signal quality, AC power or incompatibilities with speakers and/or other system components.

During the warranty period, Outlaw Audio will, at its option, either repair the defect, or replace the defective product, or the defective parts, or components thereof at no charge to the owner for parts and labor covered by this warranty. If necessary repairs are not covered by this warranty, or if a unit is examined which is not in need of repair, you will be charged for the repairs and/or the examination. If non-warranted repairs are needed, we will notify you of the estimated cost and ask for your authorization to perform said repairs.

You must pay shipping charges incurred in getting your Product to the factory. We will pay the return shipping charges if the repairs are covered by the warranty.

Please save the original shipping cartons, as the unit MUST be returned in the original carton and packing. (Replacement cartons are available at a modest charge.)

If your product needs service, please call Outlaw Audio at 866-OUTLAWS (688-5297).

You will need to present the original bill of sale to establish the date of purchase. In the event that the proof of purchase cannot be established with the original receipt, the warranty period shall be determined by the earliest date of manufacture shown on the unit, provided that the serial number label has not been altered in any manner, or by our records relating to that serial number.

In the event that you wish to return your Outlaw Product to us for any reason, please call to arrange for a Return Authorization Number. This will ensure that your problem is discussed with a service technician who will determine if there is a quick solution to your problem.

Outlaw Audio shall not be liable for, or in any way responsible for, any incidental or consequential damages of any kind. Some states do not allow limitations on how long an implied warranty lasts and/or do not allow the exclusion of incidental or consequential damages; therefore the limitations and exclusions stated herein may not apply to you. This warranty gives you specific legal rights and you may also have other rights that vary from state to state.

THERE ARE NO WARRANTIES GIVEN BY OUTLAW AUDIO THAT EXTEND BEYOND THE DESCRIPTION GIVEN HEREIN. ANY IMPLIED WARRANTIES OF FITNESS FOR PURPOSE SOLD, MERCHANTABILITY, DESCRIPTION, QUALITY OR ANY OTHER MATTERS ARE LIMITED TO THE TERMS OF THE EXPRESSED LIMITED WARRANTY STATED HEREIN.

Products are sold on the basis of specifications applicable at the time of sale. Outlaw Audio shall have no obligation to modify products once they have been sold.

This warranty is applicable only in the United States.

For applicability in other countries, please call Outlaw Audio.

